



ME3-CL2

Electrochemical sensor

Manual

(Model: ME3-CL2)

Zhengzhou Winsen Electronics Technology Co., Ltd

ME3-CL2 gas sensor

ME3-CL2 electrochemical sensor detect gas concentration by measuring current based on the electrochemical principle, which utilizes the electrochemical oxidation process of target gas on the working electrode inside the electrolytic cell, the current produced in electrochemical reaction of the target gas are in direct proportion with its concentration while following Faraday law, then concentration of the gas could be get by measuring value of current.

1.Features

- * Low consumption
- * High precision
- * High sensitivity
- * Wide linear range
- * Good anti-interference ability
- * Excellent repeatability and stability



2 Application

Widely used in industrial and environmental fields

3. Technical Parameter

Detection gas	CL2
Measurement Range	0~10ppm
Max detecting concentration	100ppm
Sensitivity	$(0.6 \pm 0.15) \mu\text{A/ppm}$
Resolution ratio	0.1ppm
Response time (T_{90})	<60S
Bias voltage	0mV
Load resistance (recommend)	10 Ω
Repeatability	<2% output value
Stability (/ month)	<2%
Output Linearity	linear
Zero drift (-20°C ~ 40°C)	$\leq 0.2\text{ppm}$
Storage temperature	-20°C ~ 50°C
Storage Humidity	15% ~ 90% RH
Pressure range	Standard atmosphere $\pm 10\%$
Anticipated using life	2 years

4. External dimension

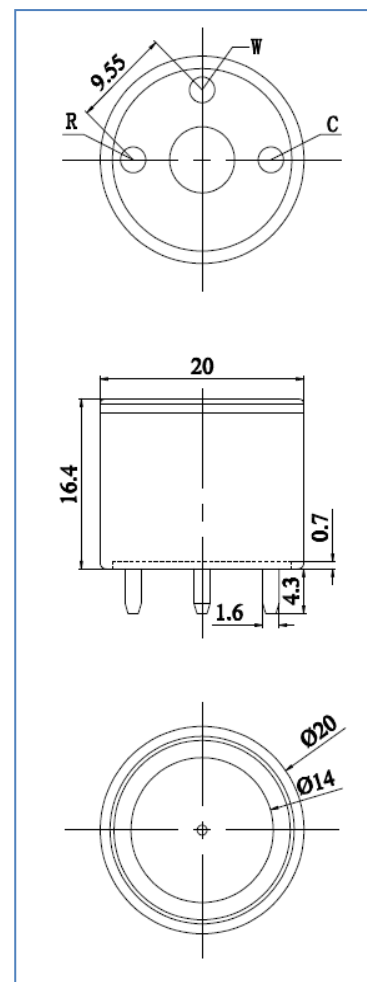

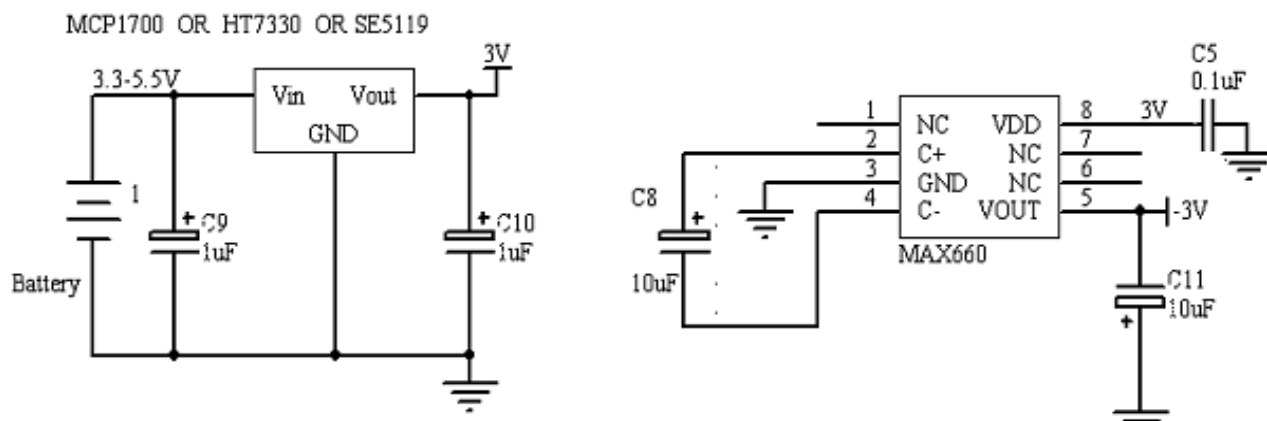

7. Anti-Interference:

ME3-CL2 sensor also responds to other gases besides target gas. Below are the response characteristics of interferential gases

Gas	Concentration	ME3-CL ₂
H ₂ S	15ppm	< -3ppm
CO	200ppm	0ppm
NO	35ppm	0ppm
SO ₂	5ppm	0ppm
H ₂ CN	10ppm	0ppm
H ₂	400ppm	0.1ppm
C ₂ H ₄	400ppm	0.1ppm
HCL	5ppm	0ppm
CO ₂	5%	0
NH ₃	20ppm	0.1ppm

8. Application Notes:

- Tin soldering is prohibited.
- Before using, power on to aging for more than 48 hours is necessary.
- Pins can't be broke off or bent.
- Don't disassemble the sensor to avoid the damage caused by electrolyte leakage.
- Avoid contacting organic solvent (including Silicone rubber and other adhesive), coatings, medicine, oil and high concentration gases.

- All the electrochemical sensors shall not be encapsulated completely by resin materials, and shall not immerse in pure oxygen environment, otherwise, it will damage the function of sensor
- All electrochemical sensors shall not be applied in corrosive gas environment, or the sensor will be damaged
- Zero calibration should be finished in clean air.
- During test and usage, sensors should avoid the gas inflow vertically
- The side for inflow can't be choked and polluted.
- The laminating film above the sensor surface can't be uncovered and damage.
- Excessive impact or vibration should be avoided
- It takes some time for the sensor to return to normal state after it is applied in high concentration gas
- Working electrode and reference electrode of the sensor shall be in short circuit when stored
- Prohibit to use the hot cement or sealant of which the curing temperature is higher than 80°C to make the capsulation for the sensor.
- Prohibit storage and usage for long time in alkaline gases with high concentration.
- Do not use the sensor when the shell is damaged

Note: To keep continual product development, we reserve right to change design features without prior notice !

Zhengzhou Winsen Electronics Technology Co., Ltd

Add.: NO.299 Jin Suo Road, National Hi-Tech Zone,
Zhengzhou, 450001 China

Tel.: 0086-371-67169097 / 61669670

Fax: 0371-60932988

E-mail: sales@winsensor.com