

## MH-440D NDIR Infrared CH4 Sensor (V2.6)

### 1. Introduction

MH-440D infrared gas sensor is a miniature universal intelligent sensor, which adopts NDIR theory to detect concentration of CH4 in air and has good selectivity, stable performance, long life, also is independent of Oxygen. The inside temperature sensor could be used for temperature compensation. This miniature infrared gas sensor is developed by the tight integration of mature infrared absorbing gas detection technology, micro machine workout and superior circuit design.

It is convenient in use and also instead of catalytic component directly, widely used in various occasions with flammable and explosion hazard gas.



### 2. Features

- High sensitivity, high resolution, low power consumption
- Output method: UART, analog voltage signal
- Temperature compensation, excellent linear output
- Excellent stability, Long lifespan
- Anti-poisons, anti-vapor interference
- Can replace catalytic type gas sensor directly

### 3. Applications

Widely used for HVAC refrigeration, air monitoring indoor, industrial-process control and safety protection, agriculture and animal husbandry.

### 4. Main Parameters

Fig1. Technical Parameters

Detection Gas	Methane
Working Voltage	3.6~5V DC (shall be supplied power by safety barrier)
Average Current	< 60mA
Interface Level	3.0V
Detection range	0~10%vol (optional)
Output Signal	UART
	0.4~2V DC (Ii 5mA) (shall be output through safety barrier)
Power source, communication terminal parameters	Ui=7.5VDC, Ii=265mA, Pi=0.5W, Ci=10 uF, Li=0mH
Warm-up time	3 min
Response time	T90<30s
Working Temperature	-20°C ~ 60°C
Working Humidity	0~95%RH (no condensation)
Sizes	Φ 20 × 21.4mm
Weight	35g
Lifetime	>5 years
Explosion-proof Mark	Exmb II T6
Defense Grade	IP54

Fig2.Measuring Range and Resolution

Target Gas	Molecular Formula	Measuring Range	Resolution	Note
Methane	CH4	0~5%VOL	0.05%VOL	Temperature compensation
		0~10%VOL	0.1%VOL	Temperature compensation

**5.Struction Size**

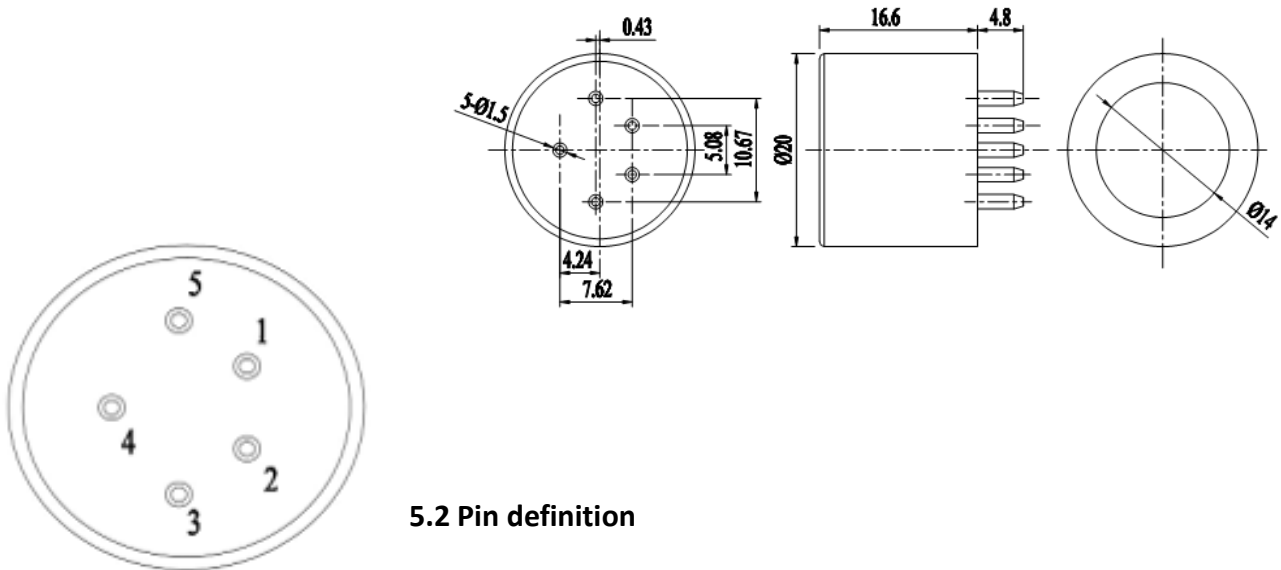

**5.2 Pin definition**

- 1-GND
- 2-Vin power supply (3.6-5V DC Pi 0.5W)
- 3-UART (RXD) 0~3.0V data input
- 4-Vout (0.4~2V Ii 5mA)
- 5- UART (TXD) 0~3.0V data output Vout

**6.Application circuit**

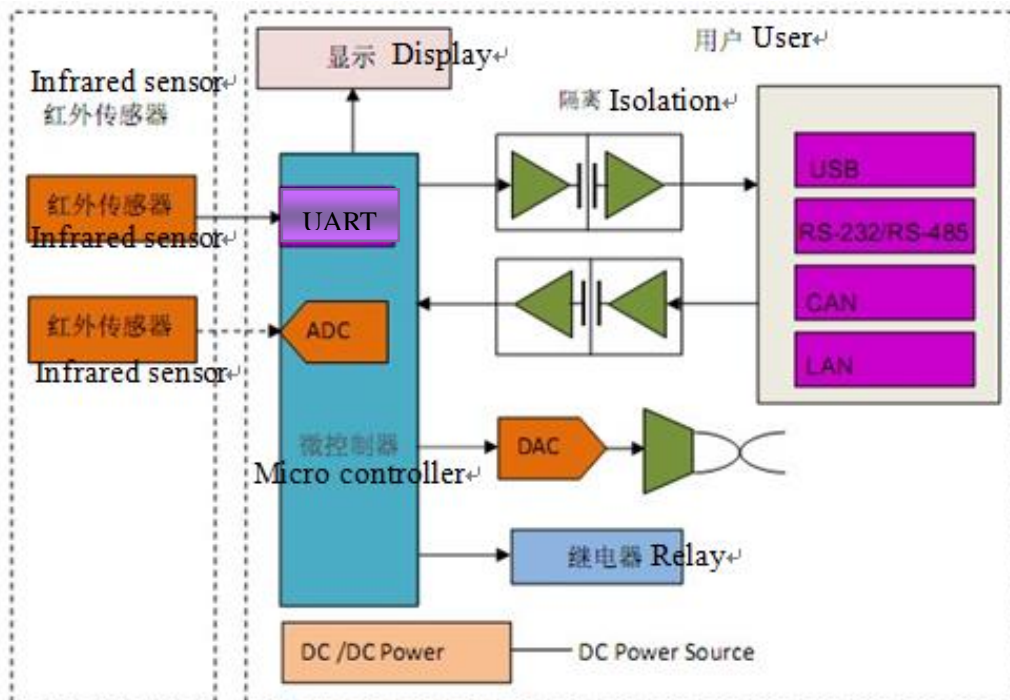

## 6.1 Analog Output

The output of Vout is proportional to the gas concentration, 0.4-2.0V output stands for 0 to full range.

Connection: Vin -5V, GND- Power Ground, Vout-ADC input.

After warm-up, If self-checking detect a fault, output voltage is 0V.

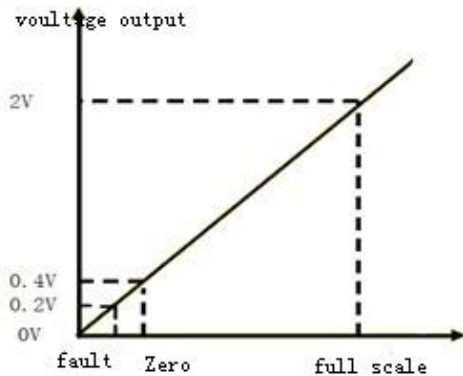

## 6.2 Digital Output

Connections: Vin-5V power, GND- Power Ground, RXD - TXD of detector, TXD - RXD of detector.

Users can read gas concentration via UART interface of sensor.

### 6.2.1 UART Communication Protocol

Baud rate: 9600; 8-bit data, 1 stop bit, no calibrating bit

Each command includes 9 byte,

beginning with 0xff,

command includes sensor no. (default is 0x01),

ending with checksum,

Command list

0x86	Reading gas concentration value
0x87	Calibrate sensor zero point (ZERO)
0x88	Calibrate span point (SPAN)

#### 1). Concentration and temperature got from gas sensor

Reading gas concentration value:

Send command								
Byte0	1	2	3	4	5	6	7	8
Start bit	Sensor no.	Command	-	-	-	-	-	checksum
0xFF	0x01	0x86	0x00	0x00	0x00	0x00	0x00	0x79

Returning

Sensor return (eg.)								
Byte0	1	2	3	4	5	6	7	8
Start bit	command	Concentration high-order	Concentration low-order	-	-	-	-	checksum
0xFF	0x86	0x02	0x60	0x47	0x00	0x00	0x00	0xD1

Calibrate zero

Send command								
Byte0	Byte1	Byte2	Byte3	Byte4	Byte5	Byte6	Byte7	Byte8
Start bit	Sensor no.	Command	-	-	-	-	-	checksum
0xFF	0x01	0x87	0x00	0x00	0x00	0x00	0x00	0x78

No returning

Calibrate span

Send command								
Byte0	Byte1	Byte2	Byte3	Byte4	Byte5	Byte6	Byte7	Byte8
Start bit	Sensor no.	Command	Span high-order	Span low-order	-	-	-	checksum
0xFF	0x01	0x88	0x07	0xD0	0x00	0x00	0x00	0xA0

No returning

**checksum** = (negation (byte1+byte2+……+byte7) )+1

Eg.read gas concentration

Send command								
Byte0	1	2	3	4	5	6	7	8
Start bit	Sensor no.	Command	-	-	-	-	-	checksum
0xFF	0x01	0x86	0x00	0x00	0x00	0x00	0x00	0x79

1. except byte0,to add all of other bytes

$$0x1 + 0x86 + 0 + 0 + 0 + 0 + 0 + 0 = 0x87$$

2. negate to above value

$$0xff - 0x87 = 0x78$$

3. add 1 to above value

$$0x78 + 0x01 = 0x79$$

Eg.

```

char getChecksum(char *packet)
{
    char i, checksum;
    for( i = 1; i < 8; i++)
    {
        checksum += packet[i];
    }
    checksum = 0xff - checksum;
    checksum += 1;
    return checksum;
}

```

## 7. Cautions for Maintenance

7.1 The sensor should be calibrated regularly. The suggested cycle time is 6 months.

7.2 Do not use the sensor in the high dusty environment for long time.

7.3 Please use the sensor with correct power supply.

7.4 Forbid to weld the sensor pins directly.

7.4 Forbid to cut the sensor pins.