

Statement

Flow Sensor

FRn03P Series

Manual



V1.1

Date: 2025.09.30

The copyright of this product datasheet belongs to Zhengzhou Winsen Electronic Technology Co., Ltd (hereinafter referred to as the Company). Without written permission, no part of this datasheet may be reproduced, translated, stored in a database or retrieval system, or disseminated by any means, electronic, photocopying, recording, or otherwise.

Thank you for using our company's series of products. To ensure optimal use of our products and reduce malfunctions caused by improper use, please read this datasheet carefully before use and follow the recommended usage methods. The Company shall not be liable for any losses resulting from failure to adhere to this datasheet or from unauthorized removal, disassembly, or replacement of internal sensor components.

The color, style, and dimensions of the product you purchased are subject to the physical product.

The Company is committed to technological progress and continuously strives for product improvement and innovation. Therefore, the Company reserves the right to make any product improvements without prior notice. When using this datasheet, please confirm it is the valid version. Simultaneously, the Company encourages users to explore optimized usage methods based on their specific applications.

Please keep this datasheet properly for future reference and assistance.

1. Product Overview:

The FRn03P series micro flow gas mass flow sensors are specifically designed for various micro-flow process control applications. This series of products utilizes the MEMS thermal principle and is suitable for dry, clean gases. The sensor features surface-mount installation, making it particularly suitable for multi-sensor integration in confined spaces.

2. Product Features:

- ✧ High sensor sensitivity with very low start-up flow
- ✧ Surface-mount installation, compact structure
- ✧ Multiple signal output options
- ✧ High stability and repeatability across the full scale

3. Product Selection:

FR_n03P-V0□-□□



4. Technical Specifications:

4.1 Technical Parameters

	Parameter	Value	Unit
Flow Measurement	Maximum Flow	50/100/200/300/400/500 1000/2000/3000/4000/5000	SCCM
	Measurement Accuracy	± (2+0.5FS)	%
	Repeatability	0.50	%
	Max. Working Pressure	500	kPa

	Pressure Drop at Max. Flow	≤60 ≤1000	Pa
	Operating Temperature	0~50	°C
Signal Output	Output Mode	Digital I ² C and Analog 0.5V~4.5VDC	
	I ² C Communication Rate	100	kHz
	Signal Response Time	≤50	ms
Electrical Parameters	Operating Voltage	5~15	VDC
	Operating Current	≤30	mA
	Electrical Interface	PH2.0-5P Plug-in Connector	
Others	Storage Temperature	-20~65	°C
	Measurement Medium	Dry, clean non-corrosive gases	

* The company's flow sensors are calibrated by default using air at 20°C, 101.325 kPa. Production conditions are temperature 22±2°C, cleanroom, (30%~35%) RH environment. If special requirements exist, calibration is performed according to customer requirements.

4.2 Structural Parameters

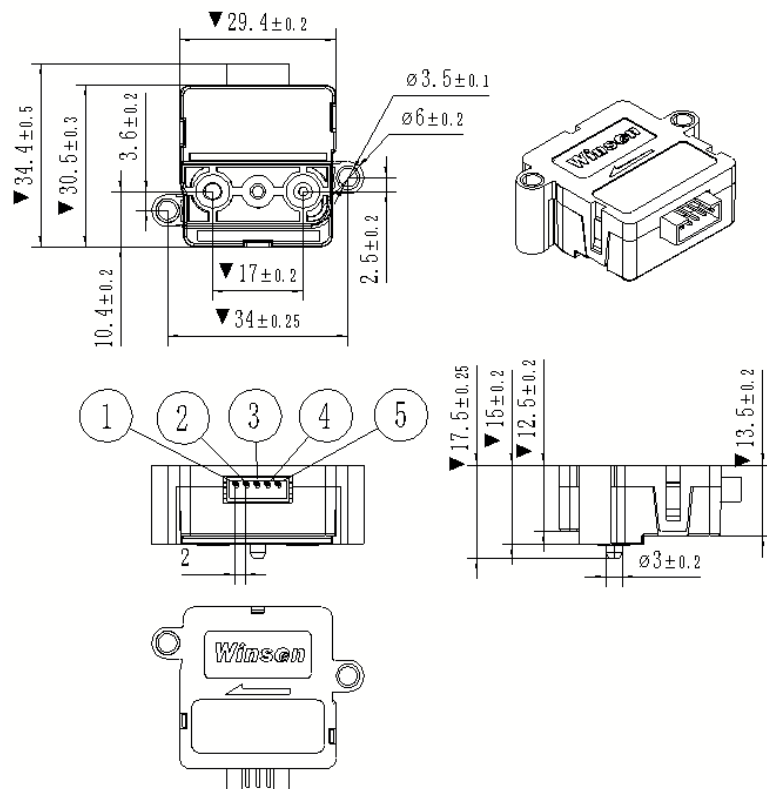

4.3 Flow Pressure Drop Curve

100/200/300/400/500SCCM	
流量 SCCM	压损 Pa
0	0
100	7
200	14
300	26
400	38
500	53

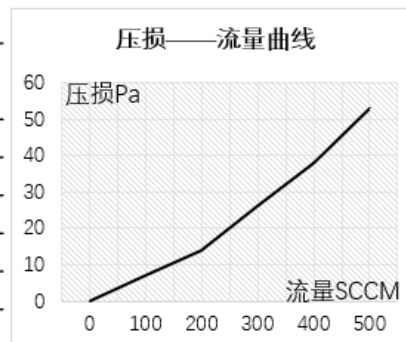

1000/2000/3000/4000/5000SCCM	
流量 SCCM	压损 Pa
0	0
1000	52
2000	185
3000	365
4000	630
5000	924

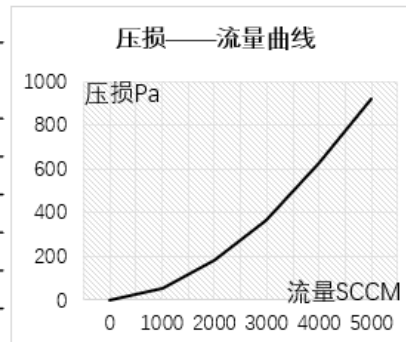

4.4 Pin Definitions

The sensor's built-in connector model is PH2.0-5P. The specific signal definitions are as follows:

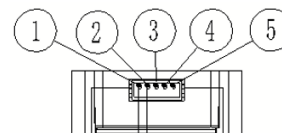

PIN1	SDA
PIN2	SCL
PIN3	GND
PIN4	VCC
PIN5	Vout+

4.5 Analog Signal Output Curve

FRn03P-V0D-50SCCM

流量 SCCM	模拟电压 mV
0	500
10	1300
20	2100
30	2900
40	3700
50	4500

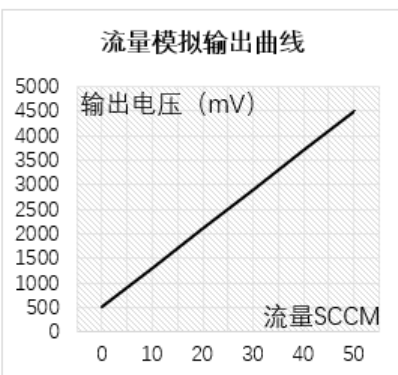

FRn03P-V0D-100SCCM

流量 SCCM	模拟电压 mV
0	500
20	1300
40	2100
60	2900
80	3700
100	4500

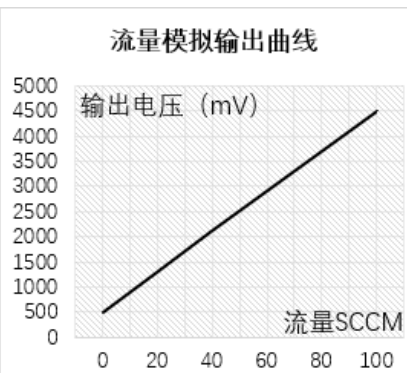

FRn03P-V0D-200SCCM

流量 SCCM	模拟电压 mV
0	500
40	1300
80	2100
120	2900
160	3700
200	4500

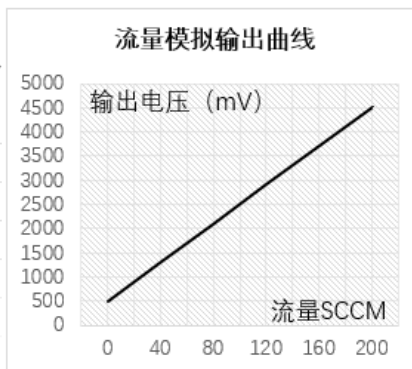

FRn03P-V0D-300SCCM

流量 SCCM	模拟电压 mV
0	500
60	1300
120	2100
180	2900
240	3700
300	4500

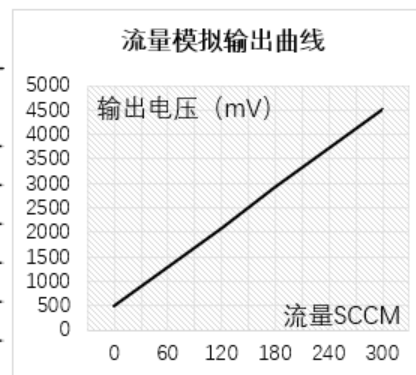

FRn03P-V0D-400SCCM

流量 SCCM	模拟电压 mV
0	500
80	1300
160	2100
240	2900
320	3700
400	4500

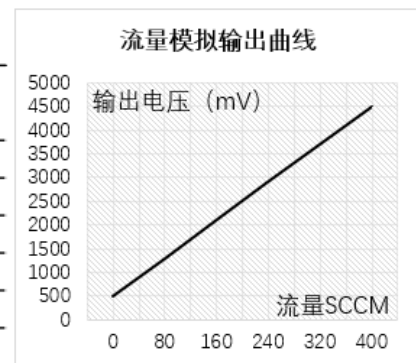

FRn03P-V0D-500SCCM

流量 SCCM	模拟电压 mV
0	500
100	1300
200	2100
300	2900
400	3700
500	4500

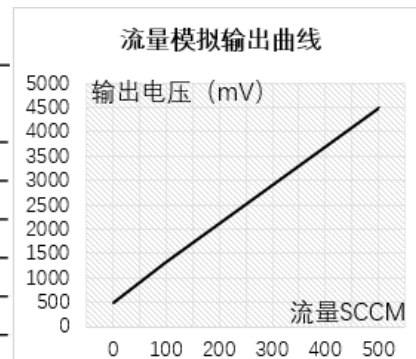

FRn03P-V0D-1000SCCM

流量 SCCM	模拟电压 mV
0	500
200	1300
400	2100
600	2900
800	3700
1000	4500

流量模拟输出曲线

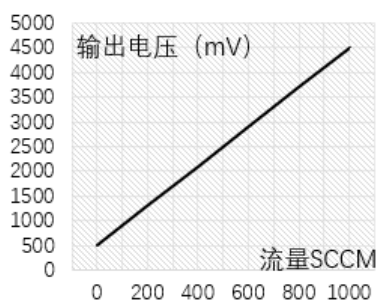

FRn03P-V0D-4000SCCM

流量 SCCM	模拟电压 mV
0	500
800	1300
1600	2100
2400	2900
3200	3700
4000	4500

流量模拟输出曲线

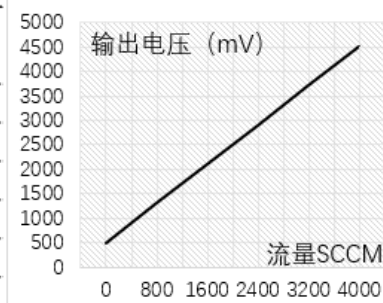

FRn03P-V0D-2000SCCM

流量 SCCM	模拟电压 mV
0	500
400	1300
800	2100
1200	2900
1600	3700
2000	4500

流量模拟输出曲线

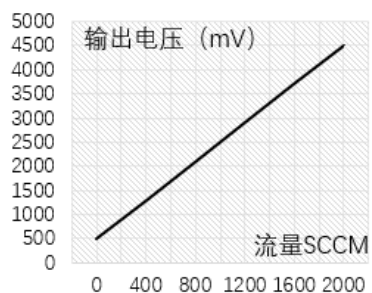

FRn03P-V0D-5000SCCM

流量 SCCM	模拟电压 mV
0	500
1000	1300
2000	2100
3000	2900
4000	3700
5000	4500

流量模拟输出曲线

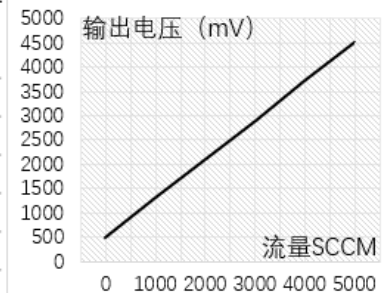

FRn03P-V0D-3000SCCM

流量 SCCM	模拟电压 mV
0	500
600	1300
1200	2100
1800	2900
2400	3700
3000	4500

流量模拟输出曲线

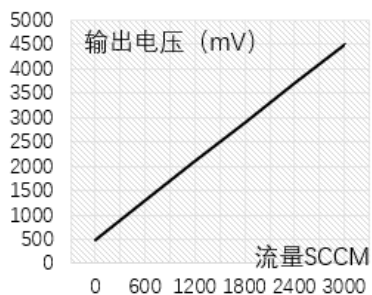

5 I²C Communication

5.1 I²C Connection

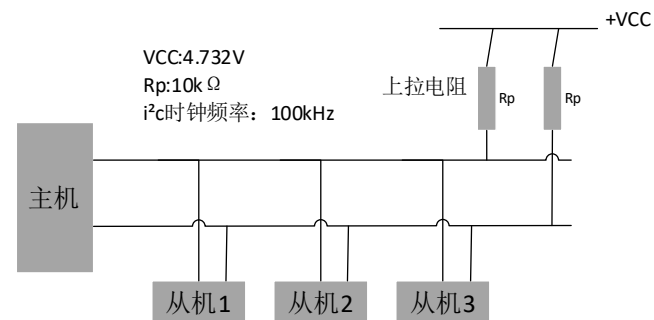

5.2 I²C Address

The default address is 0x40, followed immediately by 1 bit for Read (1) or Write (0).

5.3 I²C Communication

Start Condition (S) ----- A high-to-low transition on the SDA line while SCL is high.

Stop Condition (P) ----- A low-to-high transition on the SDA line while SCL is high.

Acknowledge (ACK) ----- The receiver pulls SDA low during the high period of SCL.

Not Acknowledge (NACK) ----- The receiver leaves SDA high during the high period of SCL.

5.4 I²C Command Codes

text	Return Bytes	Command description	Remark
0x1000	5	Read Flow Value	Read instantaneous flow value
0xCCDD	41	Read Sensor Parameters	Read sensor configuration parameters

5.5 I²C Communication Timing and Parsing

5.5.1 I²C Timing

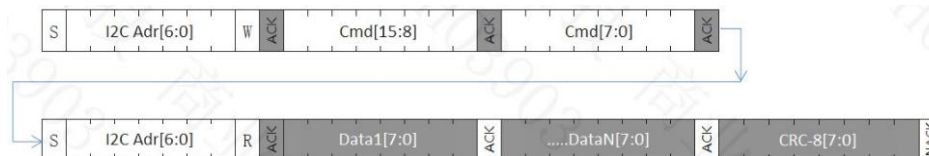

5.5.2 Read Flow Data List:

Data1	Current Flow Measurement	HEX
Data2		High byte first
Data3	/	/-

Data4		
Data5	CRC-8	Checksum

5.5.3 Read Sensor Parameters Data List:

Data1-Data4	/	/
Data5-Data6	Unit	HEX High byte first 0x15--mL/min 0x16--L/min
Data7-Data8	Full Scale	HEX High byte first
Data9-Data10	Offset	HEX High byte first
Data11-Data12	Conversion Factor	HEX High byte first
Data13-Data16	/	/
Data17-Data20	Output Voltage Lower Limit—mV	HEX High byte first
Data21-Data24	Output Voltage Upper Limit—mV	HEX High byte first
Data25-Data29	/	/
Data30-Data33	Product ID	ASCII Code Format
Data34-Data40	/	/
Data41	CRC-8	Checksum

5.5.4 Offset and Medium Coefficient Table:

Max Flow	Unit	Offset	Medium Coefficient
50~1000	SCCM	30000	25000
2000~5000	SCCM	30000	2500

5.6 Digital Flow Calculation

$$\text{Mass Flow} = \frac{\text{Flow Measurement Value} - \text{Offset}}{\text{Medium Coefficient}}$$

5.7 CRC Check

The CRC check uses CRC-8, initial value: 0x00, polynomial: $0x131 (x^8 + x^5 + x^4 + 1)$. Example code is as follows:

```
// Function Name: Calc_CRC8
// Function : CRC8 calculation, Initial Value: 0x00, Polynomial: 0x131 (x^8 +
x^5 + x^4 + 1)
// Parameters : unsigned char *data: Pointer to CRC data array
// unsigned char num: Length of CRC data
// Return : crc: Calculated CRC8 value
unsigned char Calc_CRC8(unsigned char *data, unsigned char num)
{
    unsigned char bit, byte, crc = 0x00;
    for(byte = 0; byte < num; byte++)
    {
        crc ^= data[byte];
        for(bit = 8; bit > 0; --bit)
        {
            if(crc & 0x80)
                crc = (crc << 1) ^ 0x131;
            else
                crc = (crc << 1);
        }
    }
}
```

```
}
return crc;
}
}
```

6 Installation & Usage

6.1 The gas used must be purified, free from dust, liquid, and oil contamination. If necessary, a filter device can be installed at the inlet of the gas path.

6.2 The medium pressure must not exceed 1.6 times the product's maximum working pressure, otherwise high-pressure use may lead to leakage and safety issues.

6.3 To ensure measurement accuracy in application scenarios, it is recommended to install as shown below.

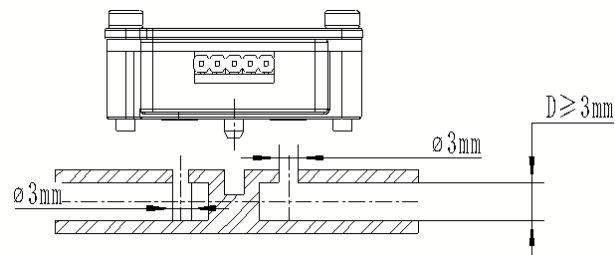

7. Troubleshooting

7.1 Preliminary Checks

- 7.1.1 Check that the gas source and inlet gas path are open.
- 7.1.2 Ensure communication lines are correctly connected.
- 7.1.3 Check that the medium pressure and ambient temperature comply with the product's technical specifications.

7.2 Fault Diagnosis

No.	Fault Phenomenon	Possible Cause	Solution
1	No signal output or output is a fixed non-zero value when no gas is flowing	Sensor damaged	Return to factory for repair
		Incorrect wiring	Check if the

			connector is plugged correctly		time is close to reference instrument		
2	No signal change when gas is flowing	Sensor installed backwards	Change installation direction	8 Disclaimer Our company shall not be liable for damages caused under the following circumstances: <ol style="list-style-type: none"> 1. Force majeure, including natural disasters, etc. 2. Failure to install, use, or operate the product in accordance with the datasheet requirements. 3. Operation or storage in unsuitable or harsh environments. 4. Unauthorized modification, alteration, disassembly, reassembly, or repair of the product by the user or any third party, resulting in product damage, personal injury, property loss, infringement of intellectual property rights, or other harmful consequences. 5. The Company reserves the final right of interpretation regarding this disclaimer. 6. This statement shall be interpreted according to the laws of Mainland China. 			
		Incorrect wiring	Check if the connector is plugged correctly				
		Sensor damaged	Return to factory for repair				
3	Sensor responds normally when gas flows, but shows specific systematic deviation compared to reference instrument	Reference standards inconsistent	Check the units used by the reference instrument and sensor and convert them				
	Sensor responds normally when gas flows, signal has significant irregular fluctuation, but the average signal over time is close to reference instrument	Turbulent flow in installation pipeline	Increase signal integration time or optimize the pipeline				
	Sensor responds normally when gas flows, but exhibits a large negative deviation	Sensor or assembly leaking	Use exclusion method to check assembly reliability first, then check sensor air tightness				
	Sensor responds normally when gas flows, signal shows specific periodic fluctuation, but the average signal over	Periodic pulsation in airflow	Increase signal integration time				

Zhengzhou Winsen Electronics Technology Co., Ltd
Add: No.299, Jinsuo Road, National Hi-Tech Zone, Zhengzhou 450001 China
Tel: +86-371-67169097 / 67169670
Fax: +86-371-60932988
E-mail: sales@winsensor.com
Website: www.winsen-sensor.com

