

Flow Sensor

FRn08



Version: 1.0

Issue Date: 2025.09.30

Zhengzhou Winsen Electronic Technology Co., Ltd

Statement

This manual copyright belongs to Zhengzhou Winsen Electronics Technology Co., LTD. Without the written permission, any part of this manual shall not be copied, translated, stored in database or retrieval system, also can't spread through electronic, copying, record ways.

Thanks for purchasing our product. In order to let customers use it better and reduce the faults caused by misuse, please read the manual carefully and operate it correctly in accordance with the instructions. If users disobey the terms or remove, disassemble change the components inside of the sensor, we shall not be responsible for the loss. The specific such as color, appearance, sizes&etc., please in kind prevail.

We are devoting ourselves to products development and technical innovation, so we reserve the right to improve the products without notice. Please confirm it is the valid version before using this manual. At the same time, users' comments on optimized using way are welcome.

Please keep the manual properly, in order to get help if you have questions during the usage in the future.

Zhengzhou Winsen Electronics Technology CO., LTD

1.Product overview:

The FRn08 series flow sensor utilizes MEMS thermal technology to monitor the flow of gaseous media in pipelines. An upgraded version of the FR08 series, this product offers significantly improved zero-point stability and full-range signal stability, making it widely applicable for various gas measurement applications.

2.Features:

- ✧ High sensor sensitivity with extremely low start-up flow rate
- ✧ Quick-connect fitting for compact installation
- ✧ Multiple signal output options
- ✧ High stability and repeatability across the full range

3.Model Selection:

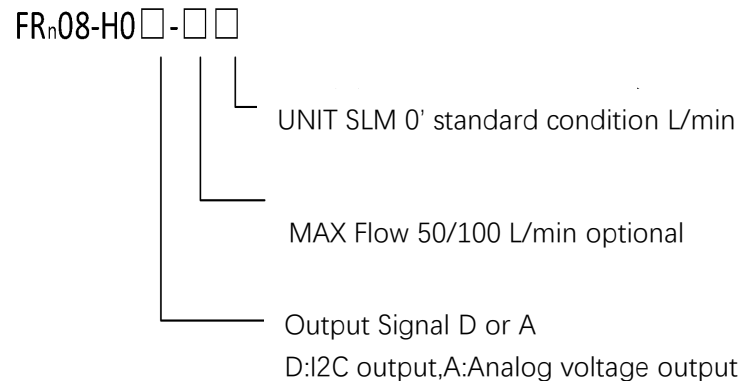

4. Technical Specifications

4.1 Technical Parameters

| | Data | Specification | Unit |
|-----------------------|-------------------------------------|--|------|
| | Bore | 8 | mm |
| Flow measurement | Max Range | 50、100L/min | SLM |
| | Accuracy | ± (2+0.5FS) | % |
| | Repeatability | 0.50 | % |
| | Max Working pressure | 400kPa | kPa |
| | Working Temperature | 0~50 | °C |
| Output | Output method | Digital output I ² C or Analog output | |
| | I ² C Communication rate | 100 | kHz |
| | Response Time | ≤50 | ms |
| Electrical parameters | Working Voltage | 5~15 | VDC |
| | Working Current | ≤30 | mA |
| | Electrical interface | PH2.0-5Pplug-in connector | |
| Other Information | Storage Temperature | -20~65 | °C |
| | Measuring medium | Dry and clean non-corrosive gas | |
| | Mechanical interface | Ø8 - 1/4" PT Pneumatic Quick-Connect Coupling | |

* Our flow sensors are calibrated by default under the following standard conditions: 20°C, 101.325 kPa, using air as the medium. Production is carried out in a controlled environment with a temperature of 22±2°C, clean atmosphere, and 30%–35% relative humidity. Calibration can be performed according to specific customer requirements when needed.

4.2 Structural Parameter

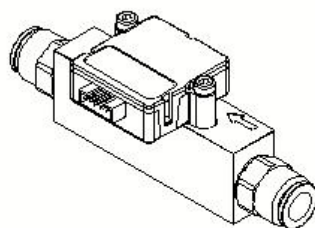
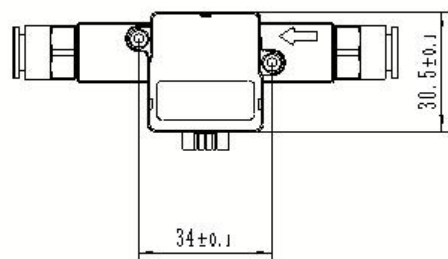
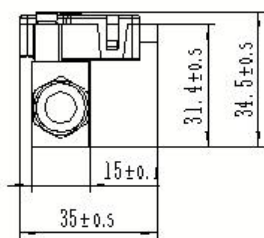
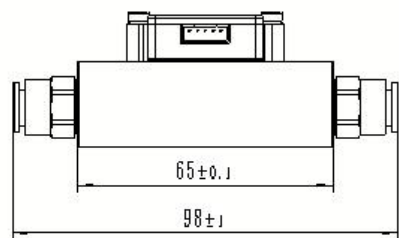
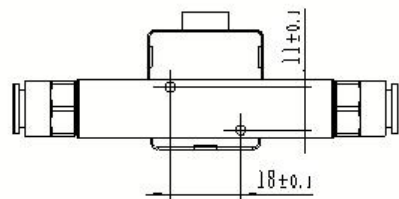

4.3 Flow pressure loss curve

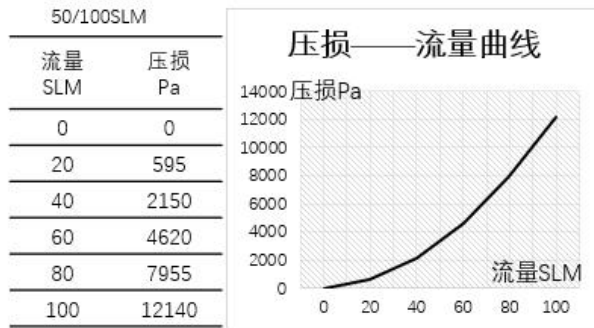

FRn08-H0D-50SLM

| 流量 SLM | 模拟电压 mV |
|--------|---------|
| 0 | 500 |
| 10 | 1300 |
| 20 | 2100 |
| 30 | 2900 |
| 40 | 3700 |
| 50 | 4500 |

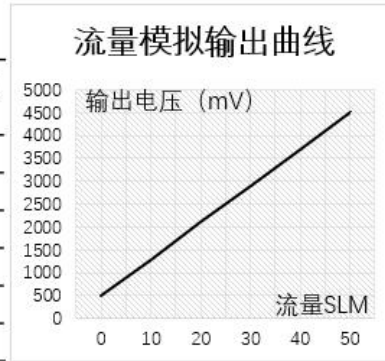

4.4 Pin Definition

The built-in connector model No. is PH2.0-5P.

:

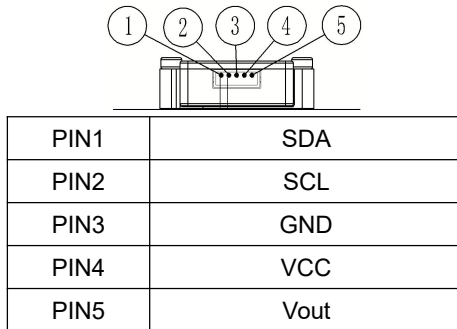

FRn08-H0D-100SLM

| 流量 SLM | 模拟电压 mV |
|--------|---------|
| 0 | 500 |
| 20 | 1300 |
| 40 | 2100 |
| 60 | 2900 |
| 80 | 3700 |
| 100 | 4500 |

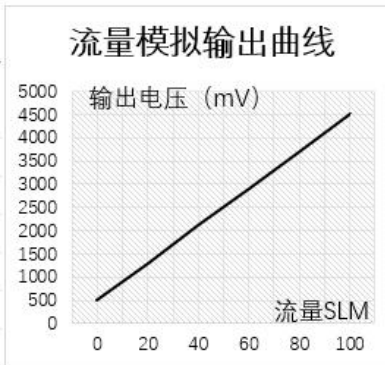

4.5 Analog Signal Output & Flow Calculation

5 I2C communication

5.1 I²C connection

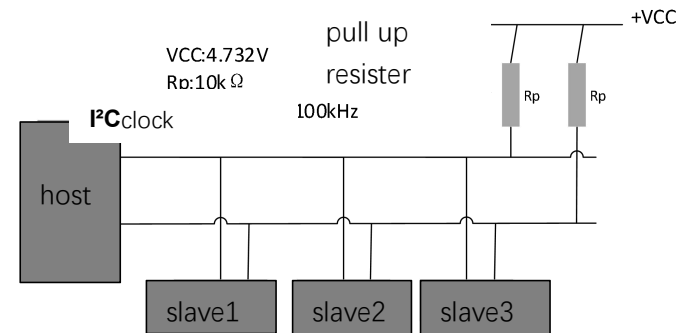

5.2 I²C Address

The default address is 0x40, followed by 1 bit indicating Read (1) or Write (0).

5.3 I²C Communication

- Start Condition (S): Generated when SDA transitions from HIGH to LOW while SCL is HIGH.
- Stop Condition (P): Generated when SDA transitions from LOW to HIGH while SCL is HIGH.
- Acknowledge (ACK): A positive pulse on SCL while SDA is held LOW.
- Not Acknowledge (NACK): A positive pulse on SCL while SDA is held HIGH.

5.4 I²C Command Codes

| Command Code | Number of bytes returned (bytes) | Command Description | Remark |
|--------------|----------------------------------|------------------------|-----------------------------------|
| 0x1000 | 5 | Read the flow value | Read the instantaneous flow value |
| 0xCCDD | 41 | Read sensor parameters | Read the sensor configuration |

5.5 I²C Communication Timing and Protocol

5.5.1 I²C Timing

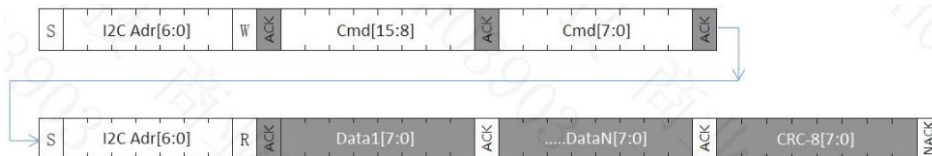

5.5.2 Reading Flow Data Sequence:

| | | |
|-------|--------------|-----|
| Data1 | Current flow | HEX |
|-------|--------------|-----|

| | | |
|-------|-------------------|------------------------|
| Data2 | measurement value | High byte in the front |
| Data3 | / | /- |
| Data4 | | |
| Data5 | CRC-8 | Check value |

5.5.3 Read the sensor parameter data list:

| | | |
|---------------|----------------------------------|--|
| Data1-Data4 | / | / |
| Data5-Data6 | Unit | HEX High byte in the front 0x15--mL/min 0x16--L/min |
| Data7-Data8 | Range | HEX High byte in the front |
| Data9-Data10 | Offset | HEX High byte in the front |
| Data11-Data12 | Conversion factor | |
| Data13-Data16 | / | / |
| Data17-Data20 | Lower limit of output voltage—mV | HEX High byte in the front |
| Data21-Data24 | Upper limit of output voltage—mV | |
| Data25-Data29 | / | / |
| Data30-Data33 | Product ID | ASCII code format |
| Data34- | / | / |

| | | |
|--------|-------|-------------|
| Data40 | | |
| Data41 | CRC-8 | Check value |

5.5.4 Offset and Medium Coefficient Table:

| Max Flow | Unit | Offset | Medium coefficient |
|----------|------|--------|--------------------|
| 50 | SLM | 30000 | 500 |
| 100 | SLM | 10000 | 500 |

5.6 Digital Flow Calculation

$$\text{Mass Flow} = \frac{\text{Flow Measurement Value} - \text{offset}}{\text{Conversion Factor}}$$

5.7 CRC Checksum

The CRC checksum adopts CRC-8 with an initial value of 0x00 and polynomial 0x131 ($x^8 + x^5 + x^4 + 1$). Example code is as follows:

```
// Function Name: Calc_CRC8
// Function: CRC8 calculation. Initial value: 0x00, Polynomial: 0x131 ( $x^8 + x^5 + x^4 + 1$ )
// Parameters: unsigned char *data: Pointer to the CRC data array
// unsigned char num: Length of CRC data
// Return: crc: Calculated CRC8 value
```

```
unsigned char Calc_CRC8(unsigned char *data, unsigned char num)
{
    unsigned char bit, byte, crc = 0x00;
    for(byte = 0; byte < num; byte++)
    {
        crc ^= data[byte];
        for(bit = 8; bit > 0; --bit)
        {
```

```
            if(crc & 0x80)
                crc = (crc << 1)^0x131;
            else
                crc = (crc << 1);
        }
    }
    return crc;
}
```

6. Installation and Usage

Due to the low pressure drop of the sensor, the flow cannot be fully regulated by the sensor itself. The piping connected to the sensor may also affect the distribution of airflow passing through the sensor, thereby influencing measurement results. To achieve optimal measurement performance, a laminar flow configuration is recommended whenever possible. Details are as follows:

6.1 The gas used must be purified, free from dust, liquids, or oil contamination. If necessary, a filtration device can be installed at the gas inlet.

6.2 The medium pressure shall not exceed 1.6 times the maximum operating pressure of the product.

6.3 To ensure measurement accuracy in application scenarios, it is recommended to install a straight pipe section of at least 5 times the nominal diameter at the sensor inlet and at least 3 times at the outlet. The installation shall be implemented as follows:

6.3.1 PT 1/4-∅ 8mm pneumatic connectors should be used on both sides of the sensor, connected with PU tubing outer diameter ∅ 8mm/inner diameter ∅ 6mm or stainless steel tubing of the same specification.

6.3.2 The requirements in section 6.3.1 shall be followed as a general rule. If the actual application differs, consult the manufacturer for evaluation.

7. Fault Diagnosis

7.1 Preliminary Checks

7.1.1 Check that the gas source and inlet pipeline are open.

7.1.2 Ensure communication lines are correctly connected.

7.1.3 Verify that medium pressure and ambient temperature comply with product specifications.

7.2 Troubleshooting

| No. | Fault phenomenon | Possible Causes | Approach |
|-----|---|--------------------------------------|--|
| 1 | When there is no ventilation, there is no signal output, or a non-zero fixed value is output. | Sensor damaged | Return to factory for repair |
| | | Wire sequence error | Check whether the terminals are plugged in correctly |
| 2 | No signal changes during ventilation | Sensor installed backwards | Change installation direction |
| | | Wire sequence error | Check whether the terminals are plugged in correctly |
| | | Sensor damaged | Return to factory for repair |
| 3 | The sensor responds normally during ventilation, | Reference standards are inconsistent | Check the measurement units used by reference |

| | | |
|--|--|---|
| but there is a specific regular deviation from the reference instrument. | | meters and sensors and convert them |
| During ventilation, the sensor responds normally, and the signal has large and irregular beats, but the average value of the sampling signal within a period of time is close to the reference instrument. | There is turbulence in the installation pipeline | Increase the signal integration time or Inspect the 5.3 line for sharp bends or sudden changes in diameter. |
| The sensor responds normally during ventilation, but there is a large negative deviation | There is a jet flow in the pipeline entering the sensor. | Refer to 5.3 Optimizing pipelines Or ask the manufacturer to jointly analyze solutions |
| During ventilation, the sensor responds normally and the signal beats in a specific pattern, but the average value of the sampling signal within a period of time is close to the reference instrument. | The air flow has periodic pulsation characteristics | Increase the signal integration time or ask the manufacturer to jointly analyze solutions. |

8. Disclaimer

Our company shall not be held liable for damages caused under the

following circumstances:

- (1) Force majeure, including natural disasters.
- (2) Failure to install, use, or operate the product in accordance with the instruction manual.
- (3) Operation or storage in unsuitable or harsh environments.
- (4) Unauthorized modifications, alterations, disassembly, reassembly, or repairs by any third party, resulting in product damage, personal injury, property loss, infringement of intellectual property rights, or other harmful consequences.
- (5) Our company reserves the final right to interpret this disclaimer.
- (6) This statement shall be interpreted in accordance with the laws of Mainland China.

Zhengzhou Winsen Electronics Technology Co., Ltd

Add: No.299, Jinsuo Road, National Hi-Tech Zone, Zhengzhou
450001 China

Tel: +86-371-67169097/67169670

Fax: +86-371-60932988

E-mail: sales@winsensor.com

Website: www.winsen-sensor.com

