



MEMS Breath Smell

Gas Sensor

(Model No.:GM-512B)

Manual

Version: 2.2

Valid from: 2020.08.25

Zhengzhou Winsen Electronics Technology Co., Ltd

Statement

This manual copyright belongs to Zhengzhou Winsen Electronics Technology Co., LTD. Without the written permission, any part of this manual shall not be copied, translated, stored in database or retrieval system, also can't spread through electronic, copying, record ways.

Thanks for purchasing our product. In order to let customers use it better and reduce the faults caused by misuse, please read the manual carefully and operate it correctly in accordance with the instructions. If users disobey the terms or remove, disassemble, change the components inside of the sensor, we shall not be responsible for the loss.

The specific such as color, appearance, sizes &etc, please in kind prevail.

We are devoting ourselves to products development and technical innovation, so we reserve the right to improve the products without notice. Please confirm it is the valid version before using this manual. At the same time, users' comments on optimized using way are welcome.

Please keep the manual properly, in order to get help if you have questions during the usage in the future.

Zhengzhou Winsen Electronics Technology CO., LTD

GM-512B MEMS Breath Smell Gas Sensor

Product description

MEMS breath smell gas sensor is using MEMS micro-fabrication hot plate on a Si substrate base, gas-sensitive materials used in the clean air with low conductivity metal oxide semiconductor material. When the sensor exposed to gas atmosphere, the conductivity is changing as the detected gas concentration in the air. The higher the concentration of the gas, the higher the conductivity. Using simple circuit can convert the change of conductivity of the gas concentration corresponding to the output signal.



Character:

MEMS technology, strong structure
 High sensitivity to H₂S, Alcohol, and acetone gas
 Small size, High sensitivity, Low power consumption
 Fast response and resume, Simple drive circuit, Long lifespan

Application

Mini breath detector

Parameters Stable1.

Part No.			GM-512B
Sensor Type			MEMS Breath Smell Gas Sensor
Standard Encapsulation			Ceramic
Detection Gas			H ₂ S, Alcohol, and acetone gas
Detection Range			0.5~50ppm (H ₂ S)
Standard Circuit Conditions	Loop Voltage	V _C	≤24V DC
	Heater Voltage	V _H	2.5V±0.1V AC or DC (high temp.)
	Load Resistance	R _L	Adjustable
Sensor character under standard test conditions	Heater Resistance	R _H	80Ω±20Ω (room temperature)
	Heater consumption	P _H	≤50mW
	sensitive materials resistance	R _S	10KΩ~100KΩ(in 5ppm H ₂ S)
	Sensitivity	S	R ₀ (in air)/R _s (in 5ppmH ₂ S)≥2
Standard test conditions	Temp. Humidity		20°C±2°C; 55%±5%RH
	Standard test circuit		V _H : 2.5V±0.1V (high temp.) V _C : 5.0V±0.1V

Sensor Structure Diagram

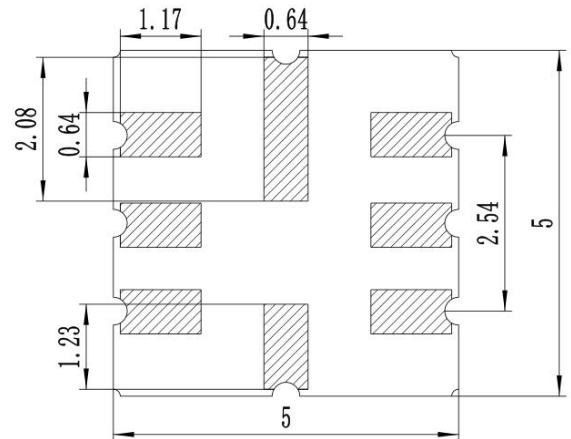
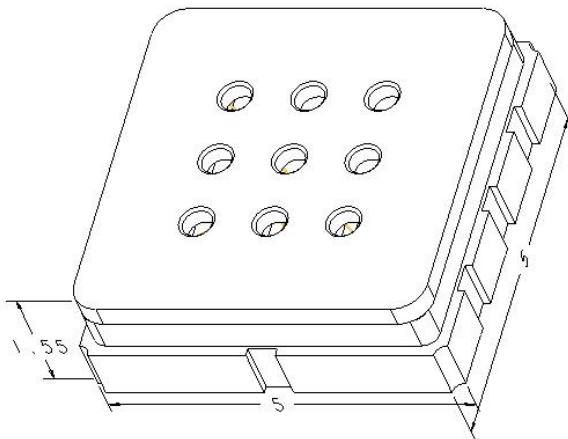

Outline

Bottom view (unit:mm)

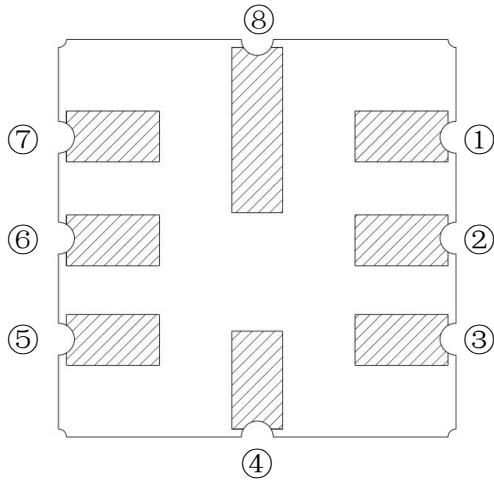

Pin	Connection
①	R _{H1}
②	
③	R _{H2}
④	
⑤	R _{S1}
⑥	
⑦	R _{S2}
⑧	

Bottom View

Basic Circuit

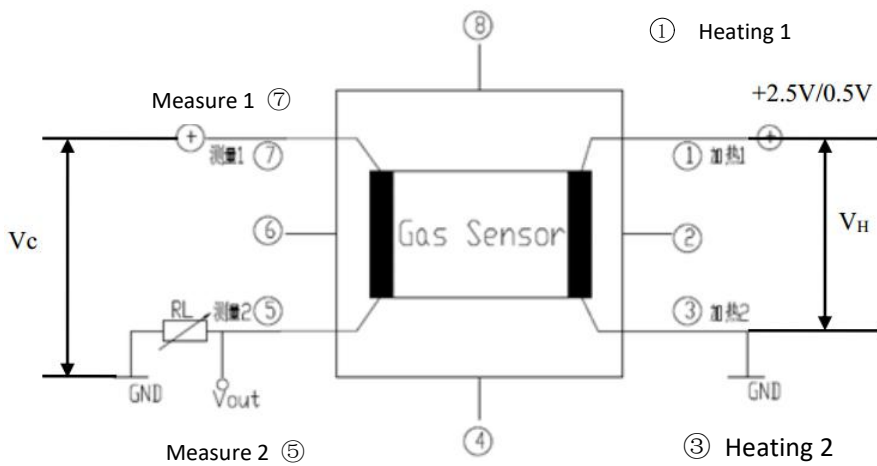

Fig2. GM-512B test circuit

Instructions: The above fig is the basic test circuit of GM-512B. The sensor requires two voltage inputs: heater voltage (V_H) and circuit voltage (V_C). V_H is used to supply specific working temperature to the sensor and it can adopt DC or AC power. V_{out} is the voltage of load resistance R_L which is in series with sensor. V_C supplies the detect voltage to load resistance R_L and it should adopt DC power.

Sensor's Characteristics:

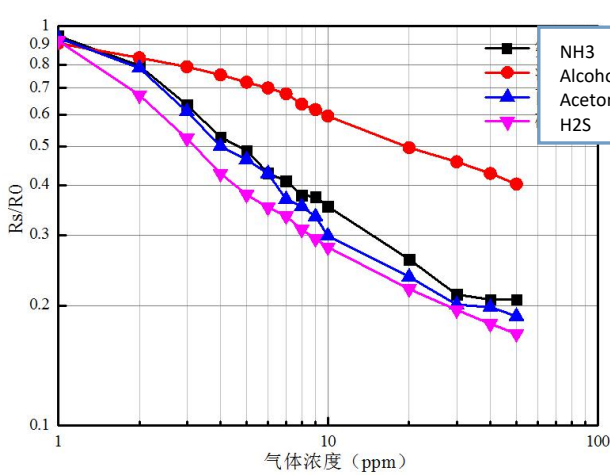

Fig3. Typical Sensitivity Curve

R_s means resistance in target gas with different concentration, R_0 means resistance of sensor in clean air. All tests are finished under standard test conditions.

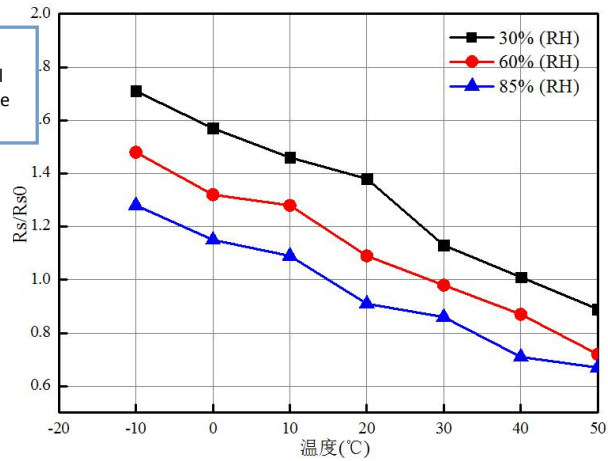

Fig4. Typical temperature/humidity characteristics

R_s means resistance of sensor in 5ppm H₂S gas under different temp. and humidity. R_{s0} means resistance of the sensor in 5ppm H₂S gas under 20°C /55%RH.

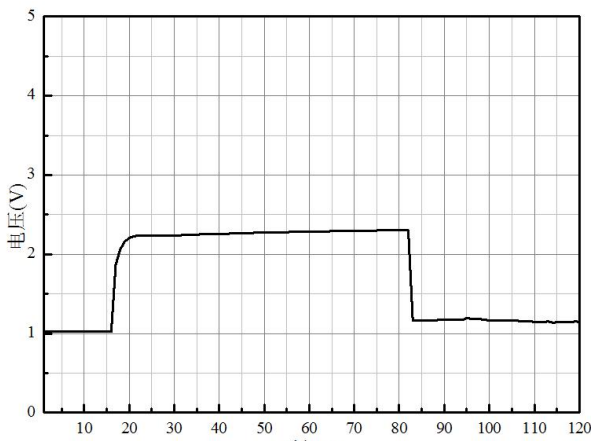

Fig5. Response and Resume

The output in above Fig is the voltage of R_L which is in series with sensor. All tests are finished under standard test conditions and the

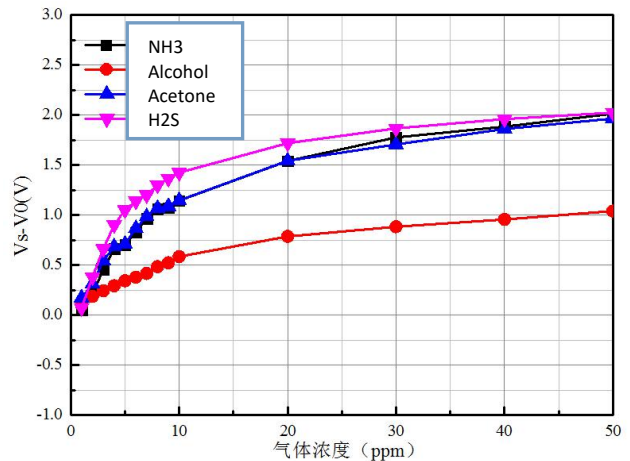

Fig6. Linearity character

The output in above Fig is the voltage of R_L which is in series with sensor. All tests are finished under standard test conditions.

Long-term stability:

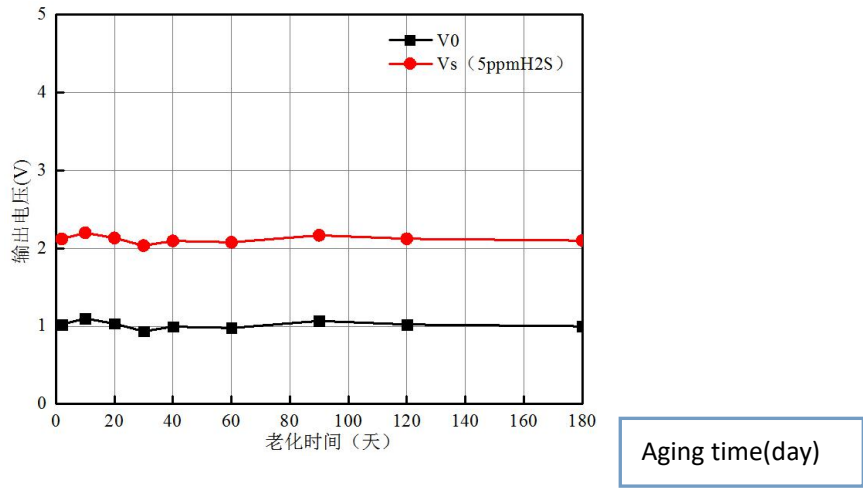

Fig7.long-term Stability

Test is finished in standard test conditions, the abscissa is observing time and the ordinate is voltage output

Instructions:

1. Preheating time

Sensor’s resistance may drift reversibly after long-term storage without power. It need to preheat the sensor to reach inside chemical equilibrium. Preheating voltage is same with heating voltage V_H . The suggested preheating time as follow:

Storage Time	Suggested aging time
Less than one month	No less than 24 hours
1 ~ 6 months	No less than 48 hours
More than six months	No less than 72 hours

2. Calibration

Sensor’s accuracy is effected by many factors such as reference resistance’s difference, the sensitivity difference, temperature, humidity, interfering gases, preheating time, the relationship between input and output is not linear, hysteretic and non-repetitive. For absolute concentration measurement, they need regular calibration (one-point calibration / multi-points calibration for full scale) to ensure that the measuring value is accurate. For relative measurement calibration is not required.

Cautions

1 .Following conditions must be prohibited

1.1 Exposed to organic silicon steam

Sensing material will lose sensitivity and never recover if the sensor absorbs organic silicon steam. Sensors must be avoid exposing to silicon bond, fixture, silicon latex, putty or plastic contain silicon environment.

1.2 High Corrosive gas

If the sensors are exposed to high concentration corrosive gas (such as H2S, SOX, Cl2, HCL etc.), it will not only result in corrosion of sensors structure, also it cause sincere sensitivity attenuation.

1.3 Alkali, Alkali metals salt, halogen pollution

The sensors performance will be changed badly if sensors be sprayed polluted by alkali metals salt especially brine, or be exposed to halogen such as fluorine.

1.4 Touch water

Sensitivity of the sensors will be reduced when spattered or dipped in water.

1.5 Freezing

Do avoid icing on sensor's surface, otherwise sensing material will be broken and lost sensitivity.

1.6 Applied voltage

Applied voltage on sensor should not be higher than 120mW, it will cause irreversible heater damaged, also hurt from static, so anti-static precautions should be taken when touching sensors.

2. Following conditions must be avoided

2.1 Water Condensation

Indoor conditions, slight water condensation will influence sensors' performance lightly. However, if water condensation on sensors surface and keep a certain period, sensors' sensitive will be decreased.

2.2 Used in high gas concentration

No matter the sensor is electrified or not, if it is placed in high gas concentration for long time, sensors characteristic will be affected. If lighter gas sprays the sensor, it will cause extremely damage.

2.3 Long time exposed to extreme environment

No matter the sensors electrified or not, if exposed to adverse environment for long time, such as high humidity, high temperature, or high pollution etc., it will influence the sensors' performance badly.

2.4 Vibration

Continual vibration will result in sensors down-lead response then break. In transportation or assembling line, pneumatic screwdriver/ultrasonic welding machine can lead this vibration.

2.5 Concussion

If sensors meet strong concussion, it may lead its lead wire disconnected.

2.6 Soldering

2.6.1 Recommended conditions for reflow soldering

Neutral atmosphere, $250\pm 10^{\circ}\text{C}$ welding temperature, avoid flux vapors

2.6.2 Recommended conditions for manual welding

Rosin soldering flux with least chlorine, $\leq 350^{\circ}\text{C}$ welding temperature, $\leq 5\text{s}$ duration time.

If disobey the above using terms, sensors sensitivity will be reduced.

Package:

The MEMS sensor has a special protective film on its surface to prevent the influence of dust, water, atmosphere and high temperature. The protective film should be removed after welding.

Adopting taping packaging method, other packaging methods can also be provided according to customer requirements.

This product is RoHS compliance.



图 8 传感器包装图

Zhengzhou Winsen Electronics Technology Co., Ltd

Add: No.299, Jinsuo Road, National Hi-Tech Zone, Zhengzhou 450001 China

Tel: +86-371-67169097/67169670

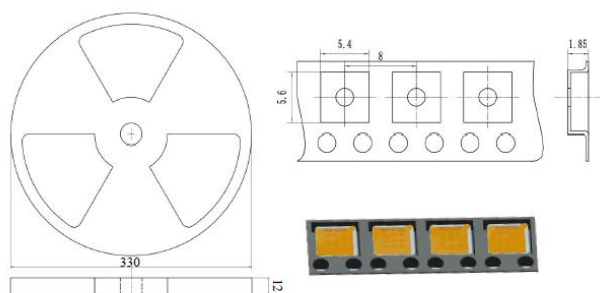
Fax: +86-371-60932988

E-mail: sales@winsensor.com

Website: www.winsen-sensor.com

