



ME3-C2H4 Electrochemical Sensor

Manual (Model: ME3-C2H4)

Version 1.1

Valid from Sep 7th 2021

Zhengzhou Winsen Electronics Technology Co., Ltd

ME3-C2H4 Electrochemical Gas Sensor

ME3-C2H4 electrochemical gas sensor make use of electrochemical oxidation process on the working electrode in electrolytic cell. And the current produced in electrochemical reaction is in direct proportion to concentration while following Faraday law. So that concentration of target gas can be tested by current.



Features

- Low consumption
- High precision & high sensitivity
- Wide range of linearity
- Good anti-interference ability
- Excellent Stability and reliability

Application

Detecting ethylene in industry and environmental protection field

Technical Parameter

Model	ME3-C2H4
Detection gas	C2H4
Detection range	0-100ppm
Max. range	200ppm
Sensitivity	$(0.070 \pm 0.015) \mu\text{A/ppm}$
Resolution	0.5ppm
Response time(T90)	<20S
Bias voltage	0mV
Load Resistance	10 Ω
Reproducibility	<2% of signal output
Output	Linearity output
Stability per month	<5%
Zero drift(-20°C-40°C)	10ppm
Tem. range	-20°C-50°C
Pressure range	standard atmosphere $\pm 10\%$
Humidity range	15%—90%RH
Anticipated using life	3 years (in air)

External dimension

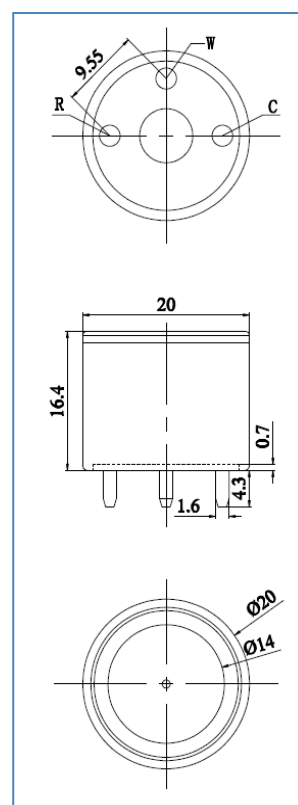

Basic circuit

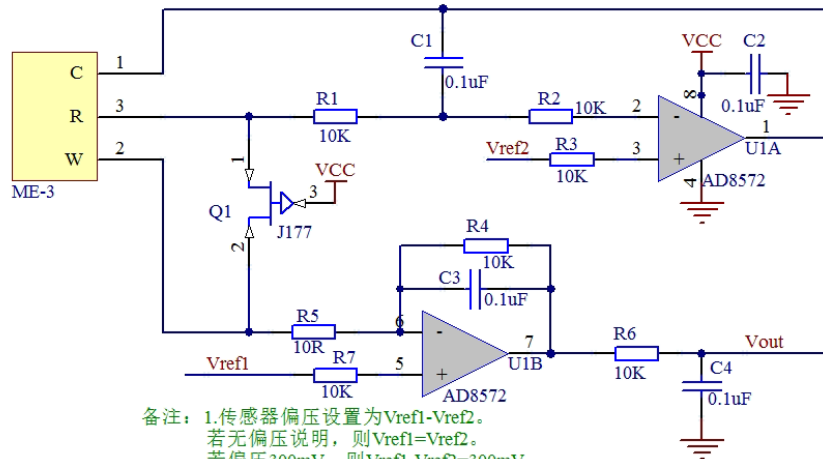

备注：1.传感器偏压设置为Vref1-Vref2。
 若无偏压说明，则Vref1=Vref2。
 若偏压300mV，则Vref1-Vref2=300mV。
 若偏压-600mV，则Vref1-Vref2=-600mV。
 2.如果偏压不为0，则Q1不焊接。
 3.建议Vref1=VCC/2。

Description of sensor characters

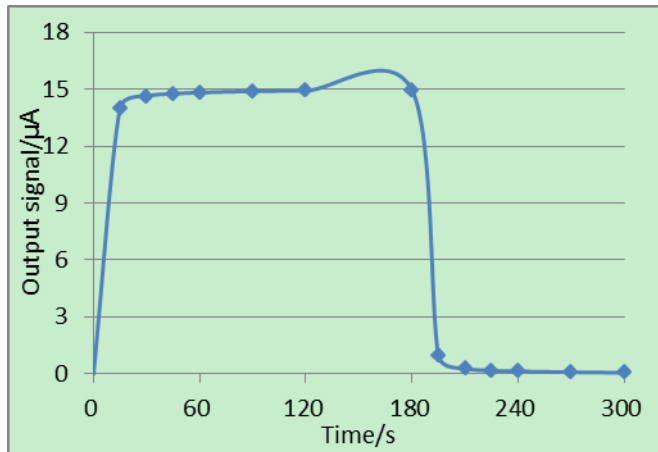

Fig3. Response and Resume

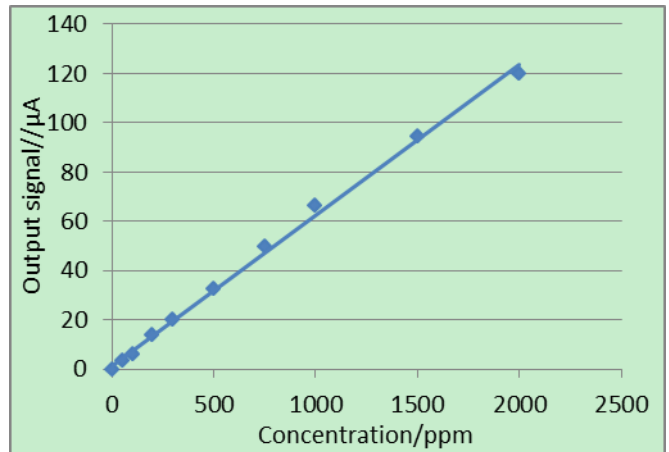

Fig4. Linearity

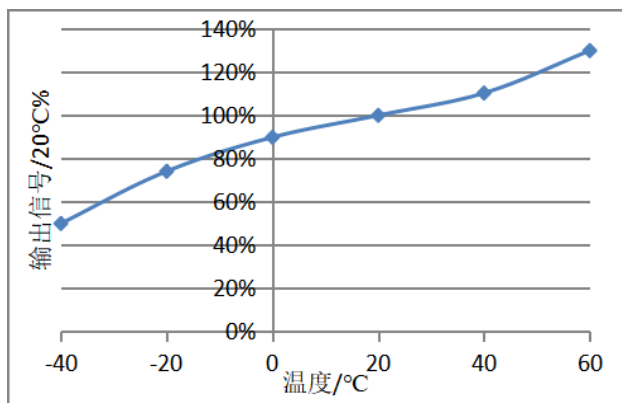

Fig5. Output of sensor at different temperature

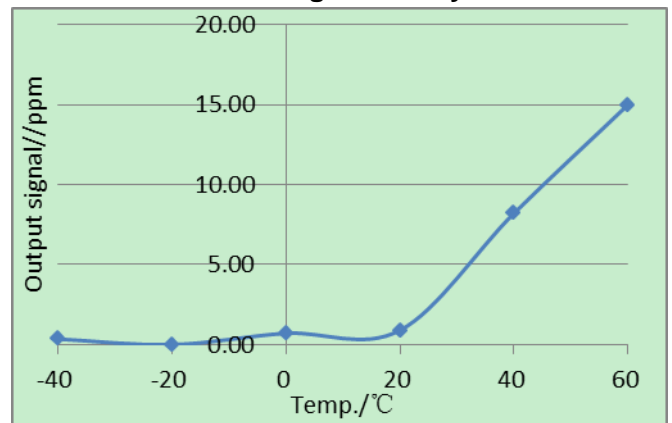

Fig6. Zero output of sensor at different temperature

Anti-Interference

Besides target gas, ME3-C2H4 sensor also responds to other gases. Below are the response characteristics of interferential gases.

Gas	Concentration	ME3-C2H4
H2S	100ppm	0ppm
SO2	20ppm	0ppm
H2	200ppm	100ppm
CO	100ppm	100ppm
NO	35ppm	9ppm
NO2	5ppm	2ppm

Application Notes

- Sensor shall avoid organic solvent, coatings, medicine, oil and high concentration gases.
- All ME Sensors shall not be encapsulated completely by resin materials, and shall not immerse in oxygen-free environment, otherwise, it will damage the function of sensor.
- All ME sensors shall not be applied in corrosive gas environment, or the sensor will be damaged.
- Please test the sensitivity of gas sensors in clean atmosphere.
- Sensors Shall be avoided to face the gas, which flow directly from front side.
- To avoid to bend and break of pins.
- Blowhole of the sensor should not be blocked and polluted, which will cause the sensitivity decrease.
- Excessive impact or vibration should be avoided.
- Do not use the sensor when the shell is damaged.
- It takes some time for the sensor to return to normal state After applied in high concentration gas.
- Do not take apart the sensor, otherwise electrolyte leakage can cause sensor damage.
- Working electrode and reference electrode of the sensor shall be in short circuit when stored.
- To preheat over 48hs before using and soldering forbidden.

Note: To keep continual product development, we reserve right to change design features without prior notice.

Zhengzhou Winsen Electronics Technology Co., Ltd

Add.: NO.299 Jin Suo Road, National Hi-Tech Zone,
Zhengzhou, 450001 China

Tel.: 0086-371-67169097

Fax: 0371-60932988

E-mail: sales@winsensor.com

