



# ME3-C8H8 Electrochemical sensor

## Manual (Model: ME3-C<sub>8</sub>H<sub>8</sub>)

Zhengzhou Winsen Electronics Technology Co., Ltd

## ME3-C<sub>8</sub>H<sub>8</sub> gas sensor

ME3-C8H8 electrochemical sensor detect gas concentration by measuring current based on the electrochemical principle, which utilizes the electrochemical oxidation process of target gas on the working electrode inside the electrolytic cell, the current produced in electrochemical reaction of the target gas are in direct proportion with its concentration while following Faraday law, then concentration of the gas could be get by measuring value of current.

### 1.Features

- \* Low consumption
- \* High precision
- \* High sensitivity
- \* Wide linear range
- \* Good anti-interference ability
- \* Excellent repeatability and stability



### 2 Application

Widely used in petroleum and petrochemical, pharmaceutical production and environmental protection field

### 3. Technical Parameter

Item	Parameter
Detection gas	C <sub>8</sub> H <sub>8</sub>
Measurement Range	0~100ppm
Max detecting concentration	200ppm
Sensitivity	(1.0±0.4) μA/ppm
Resolution ratio	0.1ppm
Response time (T <sub>90</sub> )	<120S
Bias voltage	300mV
Load resistance (recommend)	10 Ω
Repeatability	<2% output value
Stability ( / month)	<2%
Output Linearity	linear
Zero drift (-20°C~40°C)	4ppm
Storage temperature	-20°C~50°C

### 4. External dimension

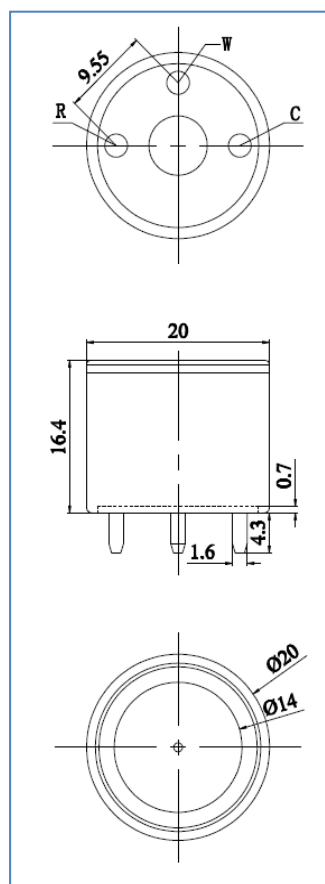

Storage Humidity	15% ~ 90% RH
Pressure range (kPa)	90-110
Anticipated using life	2 years

## 5.Characterization

Features of Sensitivity, response and output signal

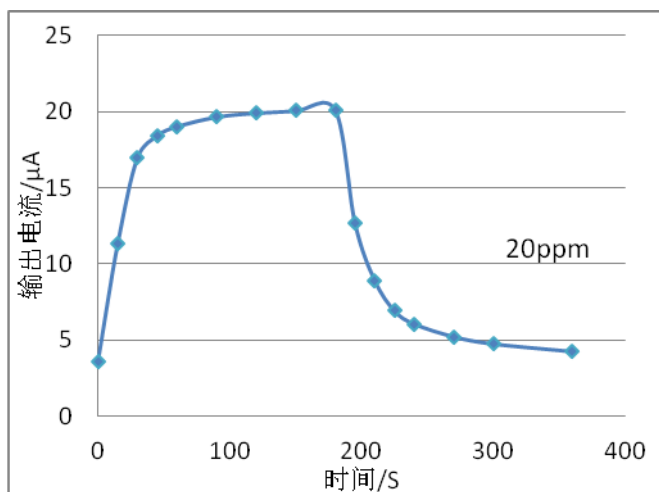

Data graph of concentration linearity features

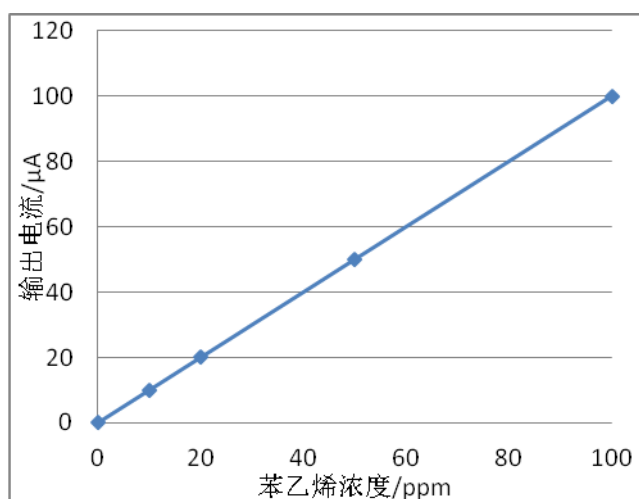

V0 Change upon Variable Temperature

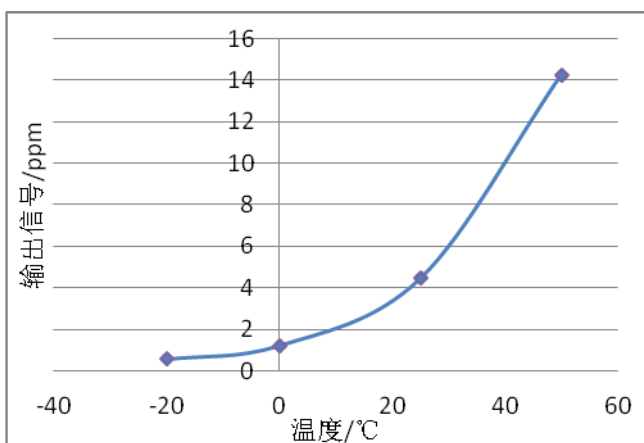

Sensitivity upon variable temperature

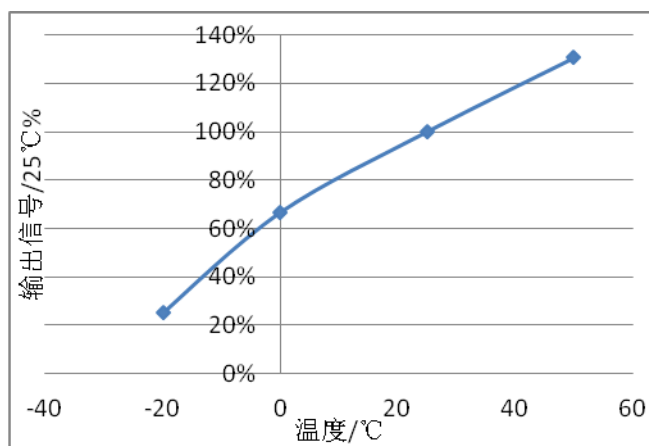

## 6. Basic circuit

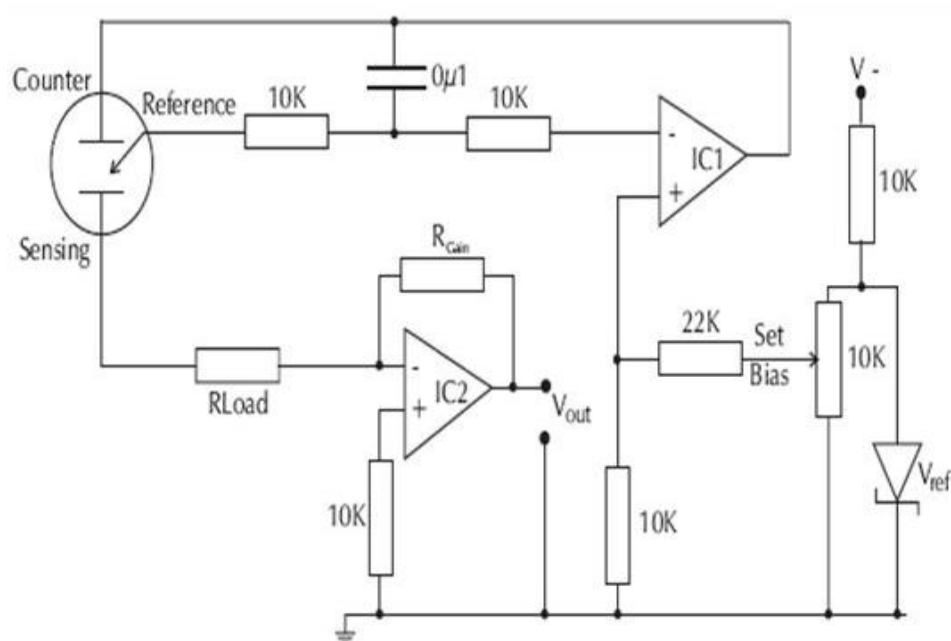

## 7. Anti-Interference:

ME3-C<sub>8</sub>H<sub>8</sub> sensor also responds to other gases besides target gas. Below are the response characteristics of interferential gases

Gas	Concentration	ME3-C <sub>8</sub> H <sub>8</sub>
CH <sub>2</sub> CHCL	100ppm	63ppm
(C <sub>2</sub> H <sub>5</sub> ) <sub>2</sub> O	50ppm	11ppm
CH <sub>3</sub> COOH	50ppm	7ppm
C <sub>6</sub> H <sub>6</sub>	50ppm	12ppm
C <sub>7</sub> H <sub>8</sub>	50ppm	19ppm
C <sub>8</sub> H <sub>10</sub>	50ppm	25ppm
CHCL <sub>3</sub>	50ppm	7ppm
CH <sub>2</sub> O	10ppm	80ppm
CO	200ppm	52ppm
C <sub>2</sub> H <sub>5</sub> OH	300ppm	155ppm
H <sub>2</sub> S	50ppm	55ppm
SO <sub>2</sub>	20ppm	6ppm
CL <sub>2</sub>	10ppm	0.5ppm

**8.Application Notes:**

- Sensor shall Avoid organic solvent, coatings, medicine, oil and high concentration gases;
- All ME Sensors shall not be encapsulated completely by resin materials, and shall not immerse in oxygen-free environment, otherwise, it will damage the function of sensor;
- All ME sensors shall not be applied in corrosive gas environment, or the sensor will be damaged;
- Please test the sensitivity of gas sensors in clean atmosphere;
- Sensors Shall be avoided to face the gas, which flow directly from front side;
- To avoid to bend and break of pins;
- Blowhole of the sensor should not be blocked and polluted, which will cause the sensitivity decrease;
- Excessive impact or vibration should be avoided;
- Do not use the sensor when the shell is damaged;
- It takes some time for the sensor to return to normal state After applied in high concentration gas;
- Do not take apart the sensor, otherwise electrolyte leakage can cause sensor damage;
- Working electrode and reference electrode of the sensor shall be in short circuit when stored.;
- To preheat over 48hs before using and soldering forbidden;

**Note: To keep continual product development, we reserve right to change design features without prior notice !**

**Zhengzhou Winsen Electronics Technology Co., Ltd**

**Add.:** NO.299 Jin Suo Road, National Hi-Tech Zone,  
Zhengzhou, 450001 China

**Tel.:** 0086-371-67169097

**Fax:**0371-60932988

**E-mail:**sales@winsensor.com