



Carbon Monoxide Gas Sensor

(Model: ME4-CO-E4)

User's Manual V1.0

Valid from May 20th,2017

Zhengzhou Winsen Electronics Technology Co., Ltd

Statement

This manual copyright belongs Zhengzhou Winsen Electronics Technology Co., LTD. Without the written permission, any part of this manual shall not be copied, translated, stored in database or retrieval system, also can't spread through electronic, copying, record ways.

Thanks for purchasing our product. In order to let customers use it better and reduce the faults caused by misuse, please read the manual carefully and operate it correctly in accordance with the instructions. If users disobey the terms or remove, disassemble, change the components inside of the sensor, we shall not be responsible for the loss.

The specific such as color, appearance, sizes &etc, please in kind prevail.

We are devoting ourselves to products development and technical innovation, so we reserve the right to improve the products without notice. Please confirm it is the valid version before using this manual. At the same time, users' comments on optimized using way are welcome.

Please keep the manual properly, in order to get help if you have questions during the usage in the future.

Zhengzhou Winsen Electronics Technology CO., LTD

ME4-CO-E4 Carbon Monoxide Gas Sensor

Profile

ME4-CO-E4 carbon monoxide gas sensor is constant potential electrolysis type. Oxidation-reduction reaction with carbon monoxide and oxygen take place respectively on the working electrode and on the counter electrode. The process releases electric charge and generates current. The current is in direct proportion to the concentration of carbon monoxide. So the concentration of the target gas could be got by measuring the value of current. The 4th electrode (auxiliary electrode) is used to compensate the zero current, to make it has the characteristics of strong signal level and low zero current.



Features

High precision, high sensitivity, short response time, good anti-interference ability, high resolution, wide linear range

Main applications

Urban atmospheric monitoring, enterprise environmental monitoring, emission gas monitoring, emergency environmental monitoring, and environmental evaluate monitoring.

Technical Parameters

Stable 1.

Detection Gas	Carbon monoxide (CO)
Detection Range	0~1000ppm
Max Range	2000ppm
Sensitivity	0.3~0.5μA/ppm
Resolution	<10ppb
Response Time (T90)	< 30S
Load Resistance	33-100Ω(recommended)
Output Linearity	linear
Stability (/month)	<10%
Zero drift (-20℃~40℃)	<±100ppb
Temperature range	-30℃~50℃
Humidity range	15%~90% RH
Pressure range	80-120kPa
Lifespan	2years (in air)

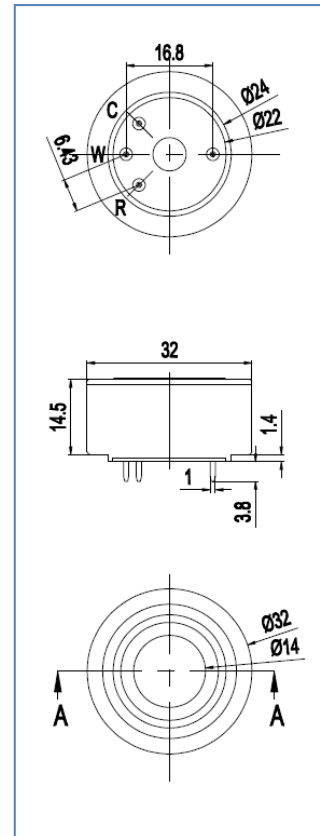

Cross Interference

ME4-CO-E4 sensor also can respond to other gases besides target gas CO. Following data are the response characteristics of the sensor to interferential gases at certain concentration for your reference.

Stable2. Cross interference

Interferential Gas	Concentration	ME4- CO-E4/ppm
H ₂ S	5	<1
NO ₂	5	<1
CL ₂	5	<1
SO ₂	5	<0.1
NO	5	<-3
H ₂	100	<10
C ₂ H ₄	100	<1
NH ₃	20	<0.1

Cautions!

- Tin soldering is prohibited.
- Before using, power on to aging for more than 48 hours is necessary.
- Pins can't be broke off or bent.
- Don't disassemble the sensor to avoid the damage caused by electrolyte leakage.
- Avoid contacting organic solvent (including Silicone rubber and other adhesive), coatings, medicine, oil and high concentration gases.
- All the electrochemical sensors shall not be encapsulated completely by resin materials, and shall not immerse in oxygen-free environment, otherwise, it will damage the function of sensor
- All electrochemical sensors shall not be applied in corrosive gas environment, or the sensor will be damaged
- Zero calibration should be finished in clean air.
- During test and usage, sensors should avoid the gas inflow vertically
- The side for inflow can't be choked and polluted.
- The laminating film above the sensor surface can't be uncovered or damage.
- Excessive impact or vibration should be avoided
- It takes some time for the sensor to return to normal state after it is applied in high concentration gas
- Working electrode and reference electrode of the sensor shall be in short circuit when stored

- Prohibit to use the hot cement or sealant of which the curing temperature is higher than 80°C to make the capsulation for the sensor.
- Prohibit storage and usage for long time in alkaline gases with high concentration.
- Do not use the sensor when the shell is damaged

Zhengzhou Winsen Electronics Technology Co., Ltd

Add: No.299, Jinsuo Road, National Hi-Tech Zone,
Zhengzhou 450001 China

Tel: +86-371-67169097/67169670

Fax: +86-371-60932988

E-mail: sales@winsensor.com

Website: www.winsen-sensor.com