



Intelligent Infrared CO₂ Gas Sensor

(Model: MH-711A)

Manual

Version: 3.5

Valid from: 5th, May 2016

Zhengzhou Winsen Electronics Technology Co., Ltd.

Statement

This manual copyright belongs to Zhengzhou Winsen Electronics Technology Co., LTD. Without the written permission, any part of this manual shall not be copied, translated, stored in database or retrieval system, also can't spread through electronic, copying, record ways.

Thanks for purchasing our product. In order to keep customers using it better and reduce the faults caused by misuse, please read the manual carefully and operate it correctly in accordance with the instructions. If users disobey the terms or remove, disassemble, change the components inside of the sensor, we shall not be responsible for the loss.

The specific such as color, appearance, sizes etc., please in kind prevail.

We are devoting ourselves to products development and technical innovation, so we reserve the right to improve the products without notice. Please confirm it is the valid version before using this manual. At the same time, users' comments on optimized using way are welcome.

Please keep the manual properly, in order to get help if you have questions during the usage in the future.

Zhengzhou Winsen Electronics Technology CO., LTD.

MH-711A Infrared CO2 Gas Sensor

1. Product Description

MH-711A is a universal type intelligent sensor to detect CO2 in air taking advantages of non-dispersive infrared (NDIR) principle. With high selectivity, no oxygen dependence, high performance and long lifespan features, MH-711A also has built-in temperature compensation feature. MH-711A is a compact and high-performance sensor based on infrared absorption of gas detection technology, micro-machining and sophisticated circuit design.



2. Characteristics

- Long lifespan
- High Sensitivity and resolution
- 5V constant power supply, low power consumption
- Output method: UART, analog voltage signal, etc.
- Quick response & Resume
- Temperature compensation, excellent linear output
- Anti-poisons, anti-vapor interference
- Detect combustible gas concentration matching with flame-proof marked detector in area 1&2 explosive environments which mix of II A, II B, II C and T1-T6 flammable gases, vapors and air

3. Application

Widely used for industrial field instrumentation, industrial-process control and safety protection

4. Technical Parameters

Product Model	MH-711A
Target Gas	CO2
Working Voltage	4.5 V ~ 5.5V DC
Average Current	< 100mA
Interface Level	3.3V
Measurement Range	0~30%VOL optional (view table 2)
Output Signal	IIC
	0.4-2V DC
Warm-up Time	3min
Response Time	T ₉₀ < 30s
Working Temp.	-40℃ ~ 70℃
Working Humidity	0 to 95%RH, Non-condensing
Dimension	Φ44×61mm
Weight	350g
Lifespan	>5 years
Ex-marking	Ex d II C T6 Gb
Protected Class	IP65

Table 1 Technical Index

Detected Gas	Measurement Range	Accuracy	Remarks
Carbon Dioxide (CO2 gas)	0~2000ppm	±50ppm +/-5% reading	Temperature compensation
	0~6000ppm		Temperature compensation
	0~1%VOL		Temperature compensation
	0~3%VOL		Temperature compensation
	0~5%VOL		Temperature compensation
	0~10%VOL	Temperature compensation	
	0-30%VOL	±15% reading	Temperature compensation

Table 2: Measurement Range and Accuracy

5. Structural Drawing

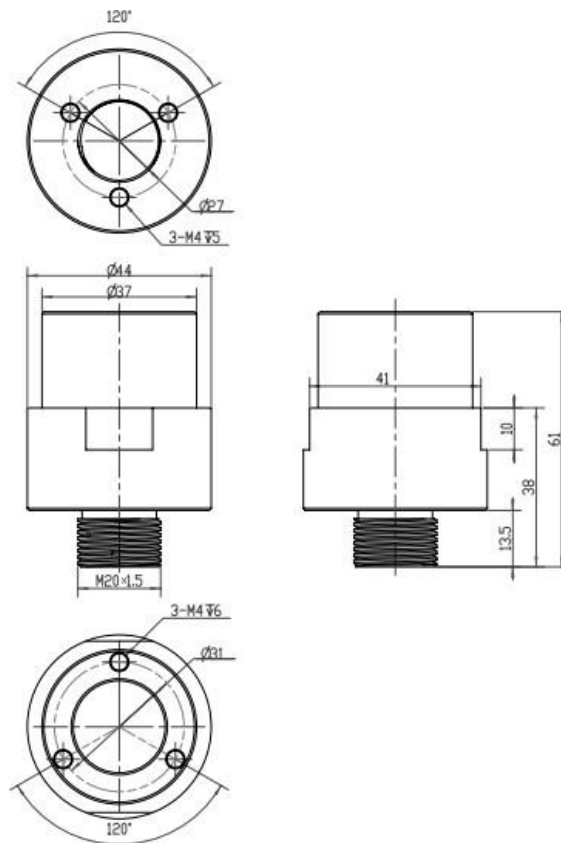

Figure 1 Structural Drawing of Sensor

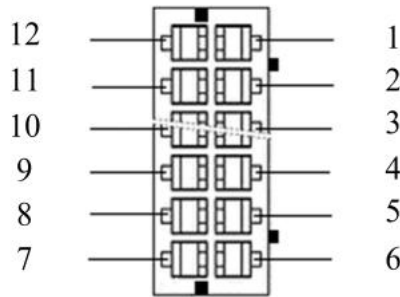

Figure 2: Pin Definition

Pin	Description
Pad1	Vin (input voltage 4.5V~5.5V)
Pad4	GND
Pad5	Vout (0.4~2V)
Pad2	IIC(SCL) clock
Pad3	IIC(SDA) data
Pad6, Pad7, Pad8 Pad10, Pad11, Pad12	Reserved, do not connect

Table 3: Definition of Pin

6. Application Circuit

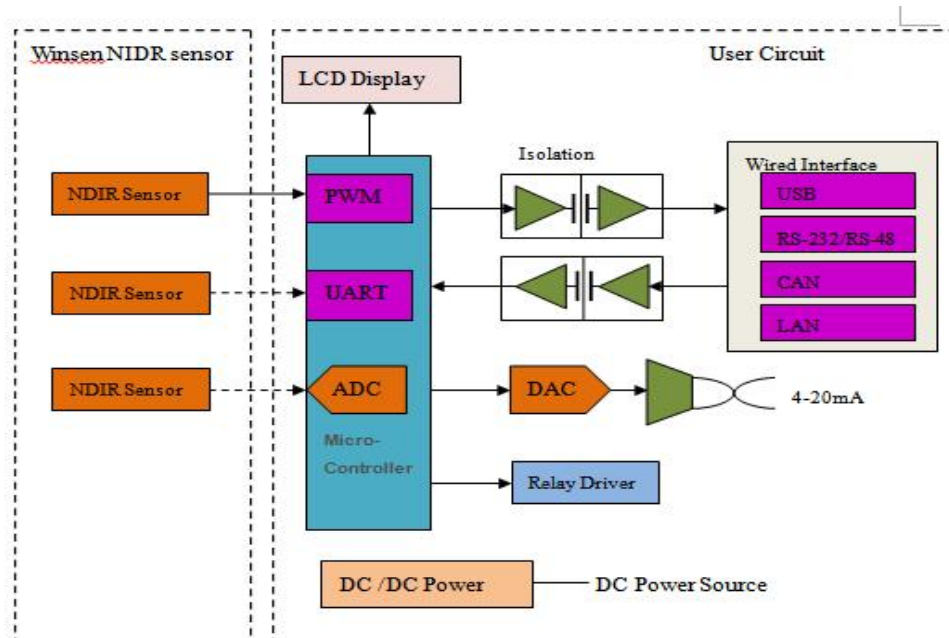

Figure 3 Application Circuit

Explanations:

6.1: Analogue Voltage Output

Voltage output range 0.4 to 2V, relatively stands for 0 to F.S.

Pad1 connect with 5V supply, Pad4 connect with VSS and Pad5 connect with input side of ADC. Then warm-up the sensor, the Vout will show a voltage value which stands for the gas concentration. If the sensor malfunctions, the output voltage is 0V.

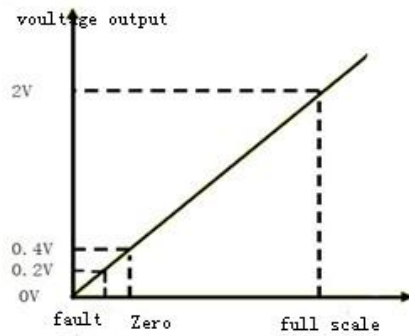

Figure 4 Analogue Voltage Output

6.2 IIC output

Hardware connection

The sensor Vin is terminated at 5V, GND is terminated at the power ground, the CLK of the user communication interface is terminated at the CLK of the detector, and SDA is terminated at the SDA of the detector. The detector can directly read the gas concentration value through the sensor's IIC interface (Note: The user's SCL and SDA signal lines must use a pull-up resistor of no more than 10K to ensure the normal operation of the IIC communication interface) without calculation

6.2.1 Communication Protocol

MH-711A is communicated through IIC bus. The module works basing IIC slave mode and can connects to external MCU,module address: 0x55, write operation address: 0xAA, read operation address: 0xAB. Every frame number data contains 10 bytes. Different host orders lead to different data and the last byte of data is the proof test value. The SCL clock frequency is recommend less than 10K.

1) Device Address

Address format: Highest seven digits are the module add of the sensor(0x55) , the least significant digit is SDIR, 0 stand for Reading, 1 stand for Writing.

A7	A6	A5	A4	A3	A2	A1	W/R
1	0	1	0	1	0	1	0/1

Table 4: Address Format

IIC communication

Write address: 0xAA, Read address: 0xAB

2) Bus Description

IIC interface protocol is a special bus signal protocol, is composed of 3 parts - Start(S), Stop(P) and binary data, as shown below.At start,SCL is high,SDA is at falling edge.After that,send the slave add.After the seven add digits is the control read&write digits,choose the read&write operation as above picWhen the slave device recognizes the corresponding add information,it sends a responsive signal to main device and SDA is pulled down at the ninth clock cycle.At stop,SCL keeps high level,SDA is at rising edge.

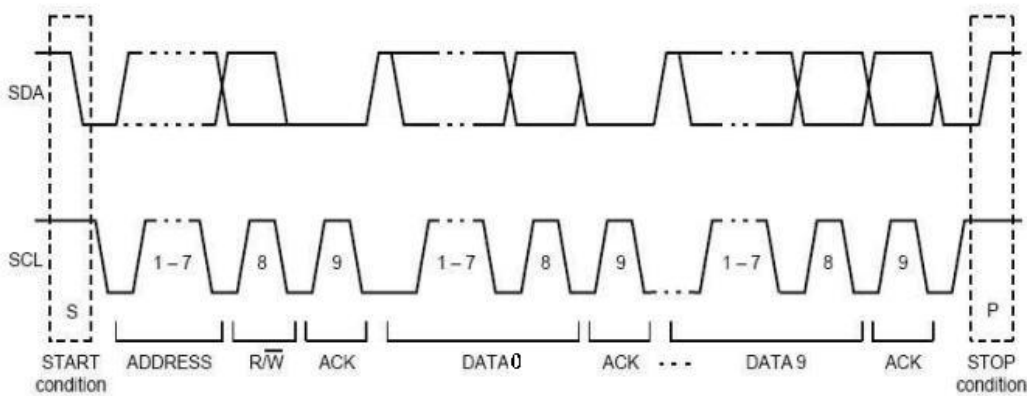

Figure 5 IIC Sequence Chart

3) Command

Every frame number data of IIC communication command contains 10 bytes. Different host orders lead to different data and the last byte of data is the proof test value.

Table 5 Command List

0x96	Gas Concentration
0xA0	Calibrate zero point (ZERO)
0xAA	Calibrate span point (SPAN)

Gas Concentration Reading

1	0x96	Gas Concentration Reading								
Send	0	1	2	3	4	5	6	7	8	9
	Command	--	--	--	--	--	--	--	--	Check Code
	0x96	0x00	0x00	0x00	0x00	0x00	0x00	0x00	0x00	0x6A
return value										
Return	0	1	2	3	4	5	6	7	8	9
	Module Status					High Density	Low Density	High Range	Low Range	Check Code
EXP.	Return									

Gas concentration= high density *256 + low density

Calibrate Zero

1	0xA0	Gas Concentration Reading								
Send	0	1	2	3	4	5	6	7	8	9
	Command	--	--	--	--	--	--	--	--	Check Code
	0xA0	0x00	0x00	0x00	0x00	0x00	0x00	0x00	0x00	0x60

EXP.	A0 00 00 00 00 00 00 00 00 60									
Return	0	1	2	3	4	5	6	7	8	9
	--	--	--	--	--	--	--	--	--	
	--	--	--	--	--	--	--	--	--	
EXP.	No value return									

Calibrate Span

1	0xAA	Gas Concentration Reading									
Send	0	1	2	3	4	5	6	7	8	9	
	Command	SPAN Value			--	--	--	--	--	--	Check Code
	0xaa	High Byte	Low Byte	0x00	0x00	0x00	0x00	0x00	0x00	0x00	0xbb
EXP.	AA 13 88 00 00 00 00 00 00 BB (Eg. calibrate 5000ppm, HEX: 0x1388)										
Return	0	1	2	3	4	5	6	7	8	9	
	--	--	--	--	--	--	--	--	--		
	--	--	--	--	--	--	--	--	--		
EXP.	No value return										

6.2.2 Calibrate and Calculate

The checksum = (invert (byte0 +... + 8)) + 1

For example, Gas Concentration Reading

	Command Sent								
Byte0	Byte1	Byte2	Byte3	Byte4	Byte5	Byte6	Byte7	Byte8	Byte9
Command	-	-	-	-	-	-	-	-	Check Value
0x96	0x00	0x00	0x00	0x00	0x00	0x00	0x00	0x00	0x6A

1. Add from Byte0 to Byte8: $0x96 + 0 + 0 + 0 + 0 + 0 + 0 + 0 + 0 = 0x96$

2. Invert: $0xff - 0x96 = 0x69$

3. Add 1: $0x69 + 0x01 = 0x6A$ after inversion

6.2.3 Example Program

C Language Calibrate & Calculate and Routine

```
char getChecksum(char *packet)
{
    char i, checksum;
    for( i = 1; i < 9; i++)
    {
        checksum += packet[i];
    }
    checksum = 0xff - checksum;
    checksum += 1;
    return checksum;
}
```

7. Notes For Maintenance

7.1 The sensor should be calibrated regularly. Recommended cycle time is once per 6 months.

7.2 Do not use the sensor in the high dusty environment for long time.

7.3 Please use the sensor with correct power supply.

Warning:

1. Sensors can only be used with detectors that have a flameproof mark and must not be used alone.
2. Do not disassemble or replace the sensor in hazardous locations. Sensor removal and replacement must be performed in a safe environment
3. It is forbidden to mount and fix in the way of perforating the sensor, such as punching holes.
4. The sensor operating voltage is 4.5 to 5.5V DC and the recommended voltage is 5V. Supply voltage exceeding 5.5V will cause permanent damage to the sensor, voltage below 4.5V DC sensor will not work
5. The sensor and the detector with explosion-proof mark can only be connected by flameproof thread, and must use the sealing ring seal that meets the explosion-proof requirements. The connection between the flameproof threads must take measures to prevent loosening

Zhengzhou Winsen Electronics Technology Co., Ltd

Add.: NO.299 Jinsuo Road, National Hi-Tech Zone,
Zhengzhou, 450001 China

Tel.: 0086-371-67169097

Fax: 0086-371-60932988

E-mail: sales@winsensor.com