



Thermopile Temperature Sensor (Model: MRT311)

User's Manual

Version: 3.0

Valid from: 2020-7-6

Zhengzhou Winsen Electronics Technology Co., Ltd

Statement

This manual copyright belongs to Zhengzhou Winsen Electronics Technology Co., LTD. Without the written permission, any part of this manual shall not be copied, translated, stored in database or retrieval system, also can't spread through electronic, copying, record ways.

Thanks for purchasing our product. In order to let customers use it better and reduce the faults caused by misuse, please read the manual carefully and operate it correctly in accordance with the instructions. If users disobey the terms or remove, disassemble, change the components inside of the sensor, we shall not be responsible for the loss.

The specific such as color, appearance, sizes &etc, please in kind prevail.

We are devoting ourselves to products development and technical innovation, so we reserve the right to improve the products without notice. Please confirm it is the valid version before using this manual. At the same time, users' comments on optimized using way are welcome.

Please keep the manual properly, in order to get help if you have questions during the usage in the future.

Zhengzhou Winsen Electronics Technology CO., LTD.

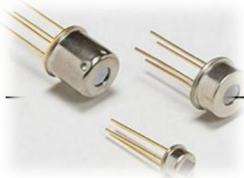

MRT311 Thermopile Temperature Sensor

TO-46 Package

MRT-311 thermopile sensor is based on MEMS technology, consists of hundreds of thermocouples connected in series. Using Seebeck principle, when there is a temperature difference between the target and the environment, the sensor gives the corresponding voltage output, therefore detecting the existence of the target or the temperature of the target.

Features

- TO-46 metal package
- High sensitivity
- Quick response, Good stability
- High filter transmittance
- High precision NTC



Applications

- Non-contact temperature measuring
- Infrared thermometer, such as ear temperature and forehead temperature measurement
- Continuous temperature control of production process
- Household appliances (Microwave oven, hair dryers, air conditioners etc), intelligent temperature induction and control system
- Human presence detection

Table 2 MRT311 thermopile parameters

Parameter	Value	Unit	Remarks
Chip size	1.1×1.1	mm	/
Field of view	95	Degree	Above 50%
Thermopile resistor	90±30	KΩ	25℃
Noise voltage	38	nV/Hz ^{1/2}	25℃
Noise equivalent power	0.23	nW/Hz ^{1/2}	500K, 1Hz, 25℃
Response rate	160±40	V/W	500K, 1Hz, 25℃
Temperature coefficient of resistance	0.06	%/℃	25℃~75℃
Time constant	≤13	ms	
Detection rate	1.5 ×10 ⁸	cmHz ^{1/2} /W	500K, 1Hz, 25℃
NTC resistance	100 ± 1%	KΩ	25℃
NTC(β)	3950 ± 1%	/	25℃/50℃
Working temperature	-30 ~ 125℃		

Sensor diagram(unit:mm)

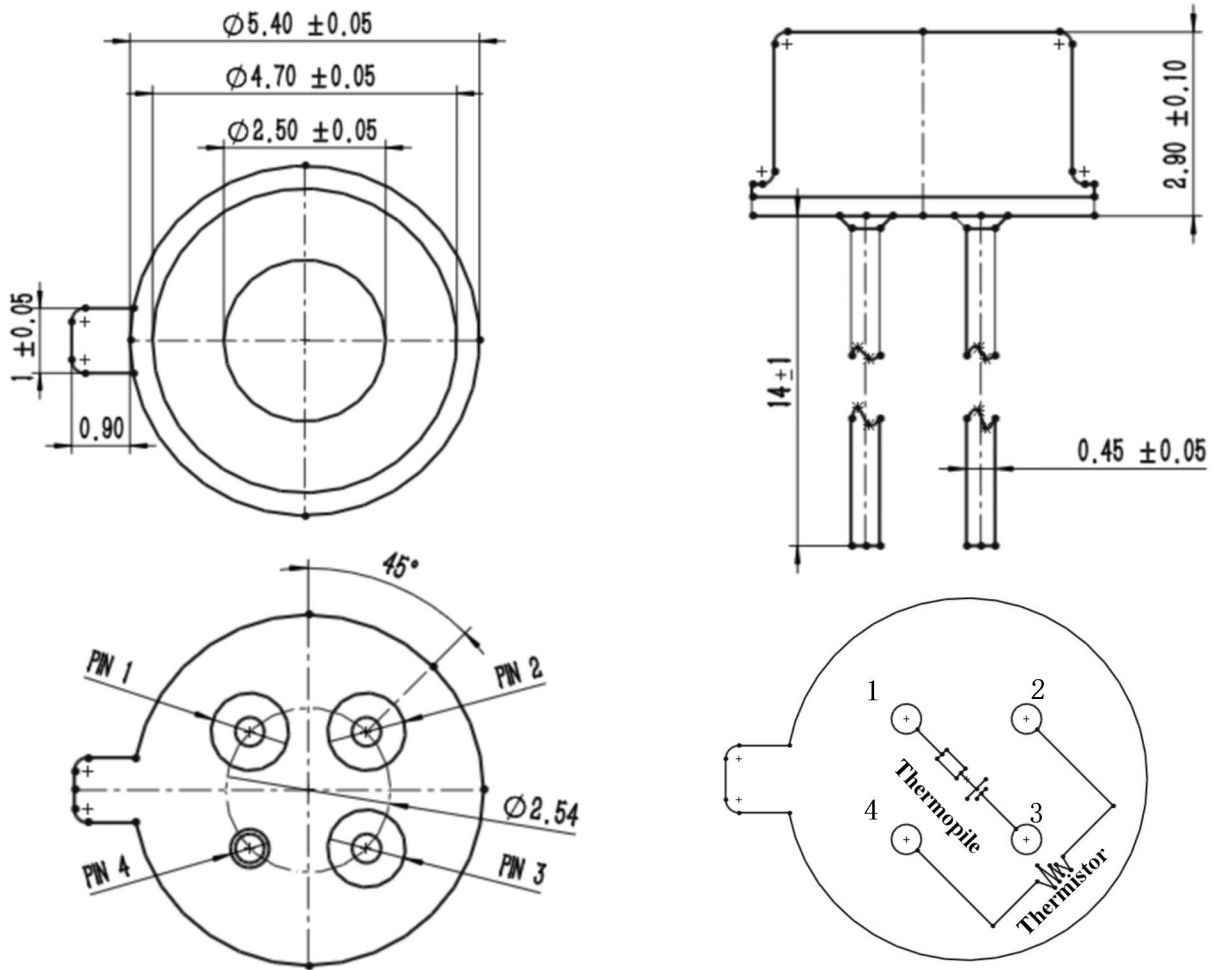

Electrode connection:

Pin	1	2	3	4
Definition	Thermopile positive	NTC	Thermopile negative	GND

Sensor Character

1. Typical thermopile performance (V-T) curve:

Testing condition: 25°C, TO-46 package, LWP5.5 filter

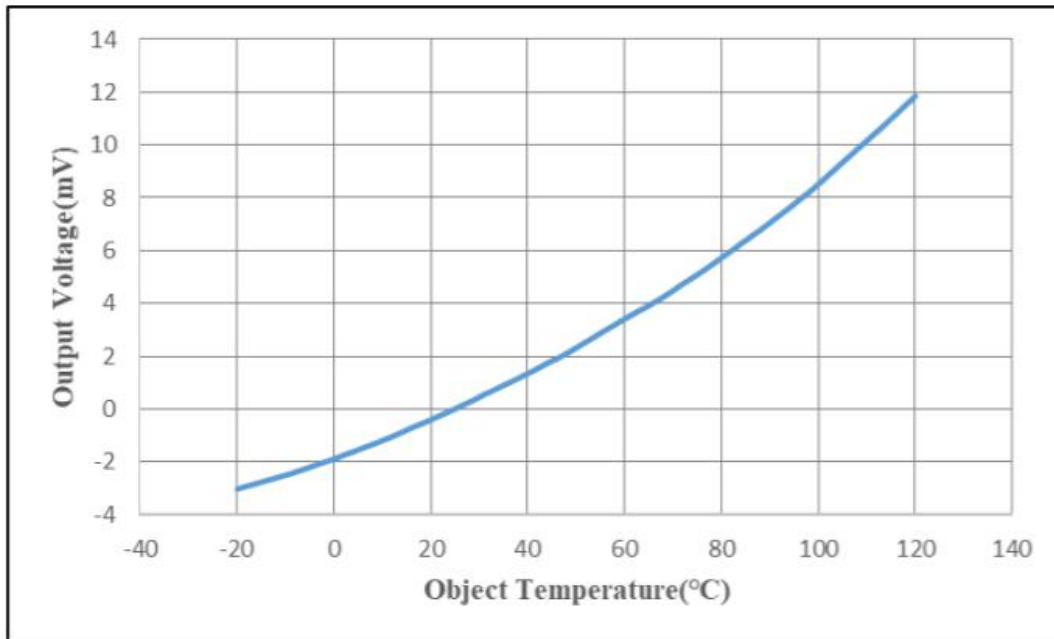

2. Filter Performance Curve

Parameter	Value	Unit	Remarks
Wavelength range	5.5~14	um	
Transmittance 1	≥75	%	Average, 5.5~14um
Transmittance 2	<1	%	<5μm

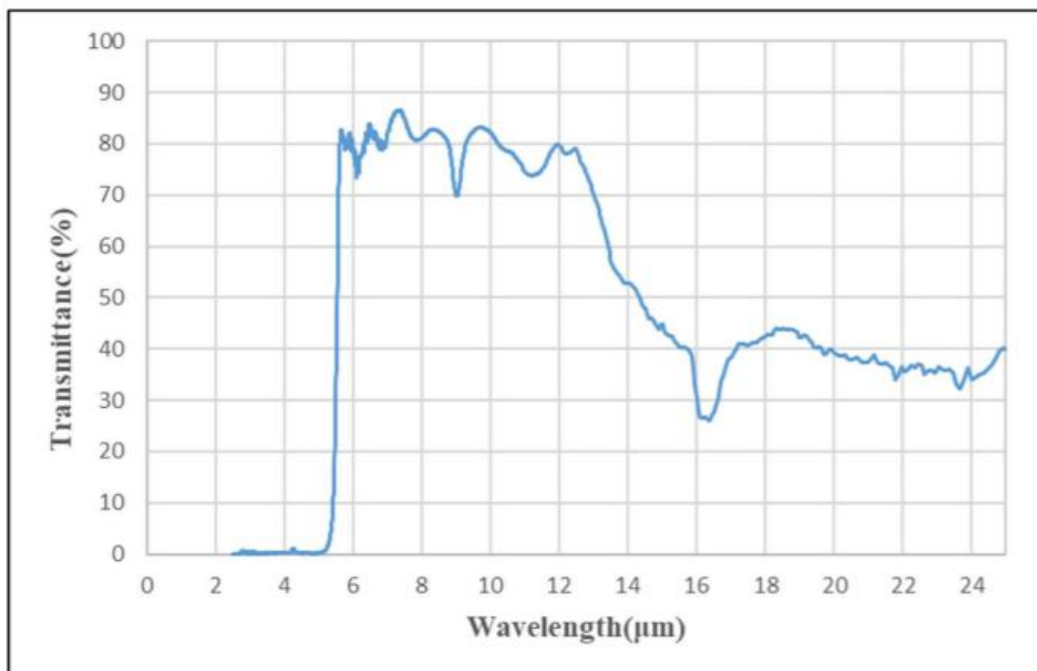

3. Thermistor (NTC) R-T Table

T(°C)	R(KΩ)	T(°C)	R(KΩ)	T(°C)	R(KΩ)	T(°C)	R(KΩ)	T(°C)	R(KΩ)
-40	3179.00	-6	439.56	28	87.80	62	22.66	96	6.97
-39	2980.73	-5	417.22	29	84.11	63	21.83	97	6.75
-38	2796.06	-4	396.14	30	80.59	64	21.05	98	6.53
-37	2623.95	-3	376.25	31	77.24	65	20.29	99	6.33
-36	2463.46	-2	357.47	32	74.04	66	19.56	100	6.13
-35	2313.73	-1	339.73	33	70.99	67	18.86	101	5.94
-34	2173.97	0	322.98	34	68.07	68	18.19	102	5.75
-33	2043.44	1	307.14	35	65.29	69	17.54	103	5.58
-32	1921.48	2	292.17	36	62.64	70	16.92	104	5.40
-31	1807.49	3	278.02	37	60.11	71	16.33	105	5.24
-30	1700.89	4	264.63	38	57.68	72	15.76	106	5.08
-29	1601.17	5	251.96	39	55.37	73	15.21	107	4.92
-28	1507.85	6	239.96	40	53.16	74	14.68	108	4.77
-27	1420.48	7	228.61	41	51.05	75	14.17	109	4.63
-26	1338.66	8	217.85	42	49.03	76	13.68	110	4.49
-25	1262.00	9	207.66	43	47.10	77	13.21	111	4.36
-24	1190.15	10	198.00	44	45.25	78	12.76	112	4.23
-23	1122.79	11	188.84	45	43.49	79	12.32	113	4.10
-22	1059.61	12	180.16	46	41.79	80	11.90	114	3.98
-21	1000.34	13	171.92	47	40.18	81	11.50	115	3.86
-20	944.72	14	164.10	48	38.63	82	11.11	116	3.75
-19	892.50	15	156.68	49	37.15	83	10.74	117	3.64
-18	843.46	16	149.63	50	35.88	84	10.38	118	3.54
-17	797.38	17	142.94	51	34.37	85	10.03	119	3.43
-16	754.09	18	136.58	52	33.06	86	9.70	120	3.34
-15	713.38	19	130.54	53	31.81	87	9.38	121	3.24
-14	675.11	20	124.79	54	30.62	88	9.07	122	3.15
-13	639.10	21	119.33	55	29.47	89	8.77	123	3.06
-12	605.22	22	114.13	56	28.37	90	8.48	124	2.97
-11	573.33	23	109.19	57	27.32	91	8.21	125	2.89
-10	543.30	24	104.48	58	26.31	92	7.94		
-9	515.01	25	100.00	59	25.34	93	7.69		
-8	488.36	26	95.73	60	24.41	94	7.44		
-7	463.24	27	91.67	61	23.51	95	7.20		

Recommended circuit:

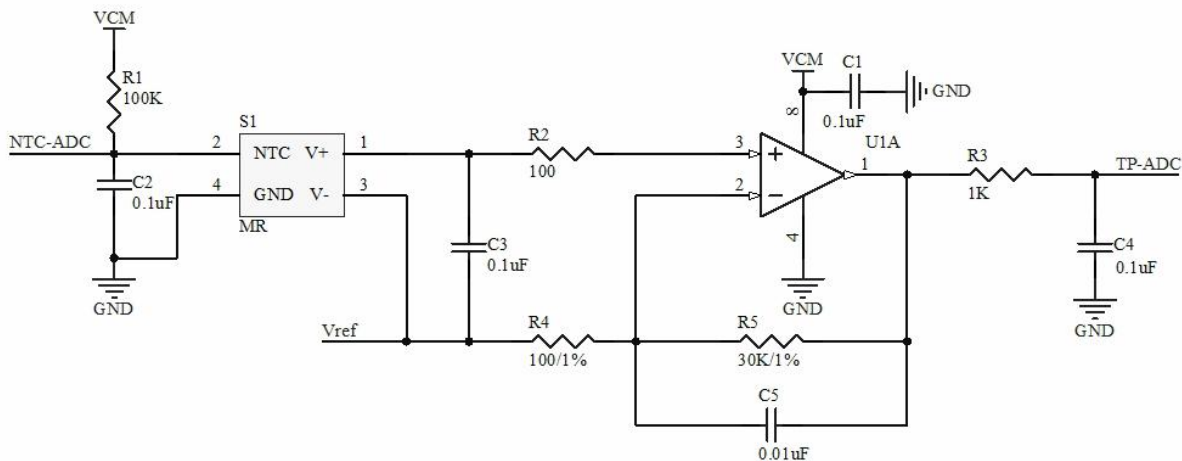

Temperature measurement step

- (1) Read the resistance value R_a between pin 2 and 4;
- (2) Find the ambient temperature T_a according to R_a 's last R-T table in the specification;
- (3) reading the voltage V_a between pin 1 and 3;
- (4) Find the voltage value equal to or close to the V_a value in the T_a column of the V-T table, and the corresponding abscissa is the temperature of the measured object.

Note:

The sensor must first calibrate the resistance of the thermistor NTC;

The sensor test is affected by factors such as black body temperature, distance, and environment. The V-T table is for reference only. The V-T meter needs to be calibrated before use.

The output voltage of the sensor is easily affected by the NTC resistance value. It is necessary to increase the thermal resistance and heat capacity to increase the temperature stability. Generally, metal (copper, aluminum) kits are used;

In order to reduce the thermal interference between the sensor pins, the sensor pins should be thermally isolated when making a PCB;

Hand soldering temperature should be $330 \pm 20^\circ\text{C}$, and single pin soldering time should not exceed 3s;

Frequent, excessive vibration, strong impact or collision will cause resonance inside the sensor to break.

Zhengzhou Winsen Electronics Technology Co., Ltd

Add: No.299, Jinsuo Road, National Hi-Tech Zone,
Zhengzhou 450001 China

Tel: +86-371-67169097/67169670

Fax: +86-371-60932988

E-mail: sales@winsensor.com

Website: www.winsen-sensor.com