



Pyroelectric Infrared Sensor (Model: RD-626W)

User's Manual

Version: 1.3

Valid from: 2021-04-30

Zhengzhou Winsen Electronics Technology Co., Ltd

Statement

This manual copyright belongs to Zhengzhou Winsen Electronics Technology Co., LTD. Without the written permission, any part of this manual shall not be copied, translated, stored in database or retrieval system, also can't spread through electronic, copying, record ways.

Thanks for purchasing our product. In order to let customers use it better and reduce the faults caused by misuse, please read the manual carefully and operate it correctly in accordance with the instructions. If users disobey the terms or remove, disassemble, change the components inside of the sensor, we shall not be responsible for the loss.

The specific such as color, appearance, sizes &etc, please in kind prevail.

We are devoting ourselves to products development and technical innovation, so we reserve the right to improve the products without notice. Please confirm it is the valid version before using this manual. At the same time, users' comments on optimized using way are welcome.

Please keep the manual properly, in order to get help if you have questions during the usage in the future.

Zhengzhou Winsen Electronics Technology CO., LTD.

RD-626W Pyroelectric Infrared Sensor

Pyroelectric Infrared Sensor detects the infrared radiation by using the temperature-dependent feature. It suppresses the interference caused by temperature change, adopts the method of dual sensing elements complementary which improves the stability of the sensor. This PIR sensor can be widely used in safety device, burglar alarm, automatic door, auto light control and intelligent toys.

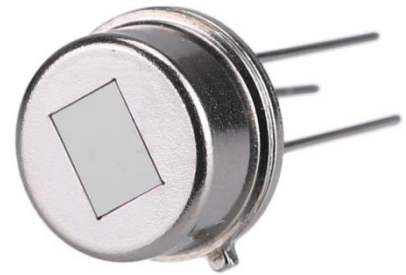

Features:

- * High sensitivity and excellent signal to noise ratio
- * Excellent resistance to EMI interference
- * Adopting dual-sensing elements compensation structure, high resistance to external environment interference
- * Strong white light resistance
- * Components and amplifiers are packaged in TO-5, which saves users time in designing and mounting

Applications

Security, intrusion alarm, and access control rooms;
 Automatic light switch, safety door;
 Smart home, smart home Appliance;

Parameters

Table 1

Model No.	RD-626W
Standard Encapsulation:	TO-5
Infrared receiving Electrode	2×1mm, 2 sensitive elements
Window Size:	3×4mm
Receiving Wavelength:	5~14μm
Transmittance	>75%
Output signal peak[Vp-p]	≥3500mV
Sensitivity	≥3200V/W
Detection Rate (D*):	1.4 ×10 ⁸ cmHz ^{1/2} /W
Noise peak[Vp-p]:	<70mV
Output balance degree:	<10%
Source Voltage:	0.3~1.1V
Current	<25uA @Rs=47K
Working Voltage:	3~15V
Working temperature:	-30~70°C
Storage temperature:	-40~80°C
Incidence angle map:	

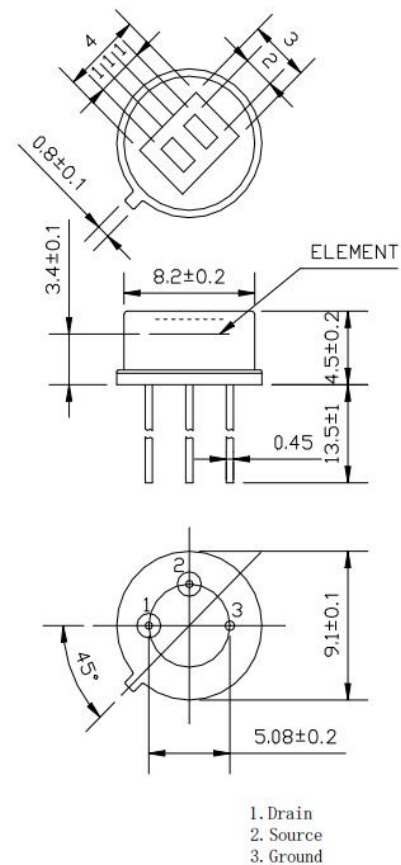

Component Structure
 Basic Testing Circuits

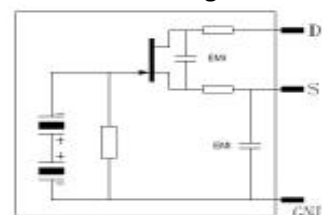

Test Method:

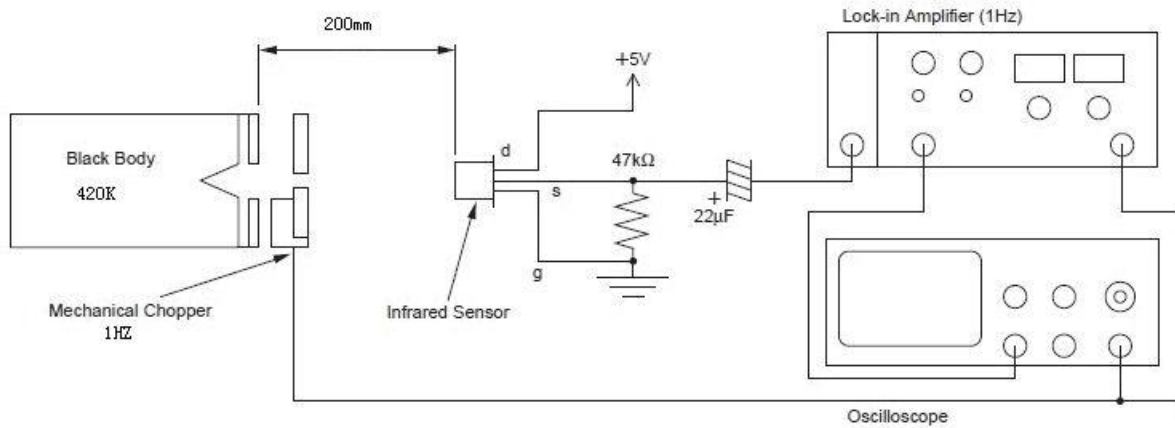

Testing Conditions:

- ◆ Environment Temperature: 25°C±1°C
- ◆ Blackbody temperature: 420K±0.1K
- ◆ Modulation frequency 1HZ, 0.3~3.5HZ Δf
- ◆ Magnification: 72.5 dB

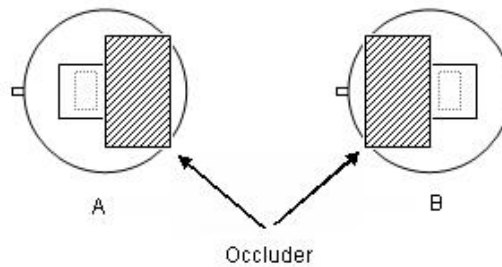

Dual sensor sensitivity balance degree can be got by detecting each cell's sensitivity (single signal output peak) and calculate in following formula:

$$\text{Balance degree} = |VA-VB|/(VA+VB) \times 100\%$$

VA = Surface A sensitivity (mVp-p)

VB = Surface B sensitivity (mVp-p)

Frequency Characteristic

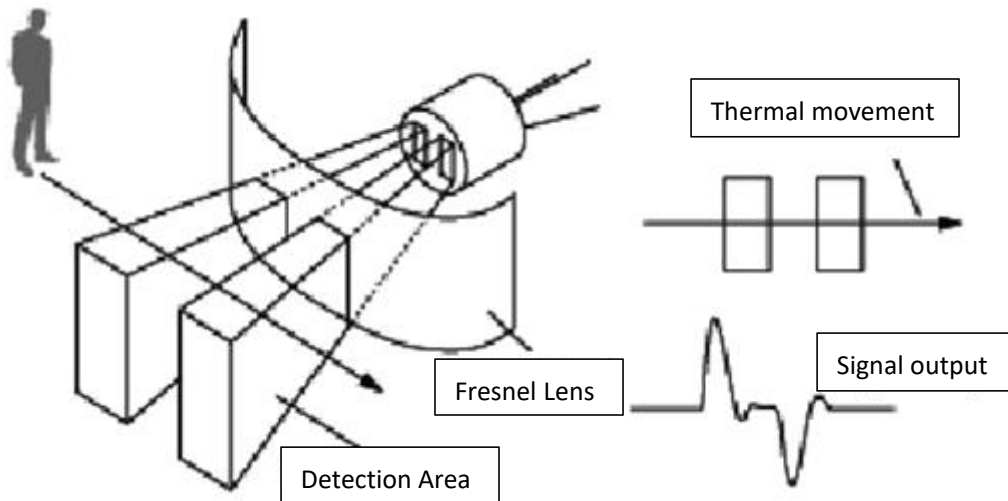

Fresnel Lens

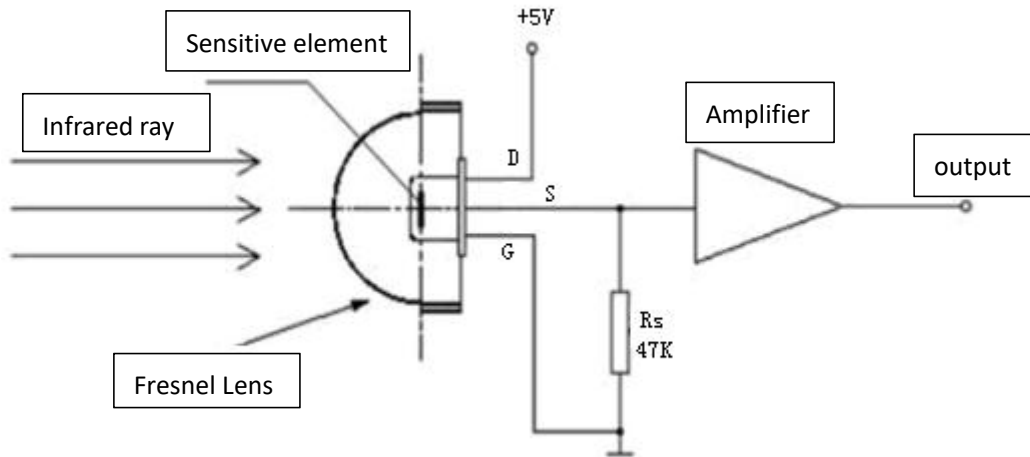

By using different Fresnel lens, the detection range and distance can be determined. According to customer's requirement, it can response to various detection range and distance.

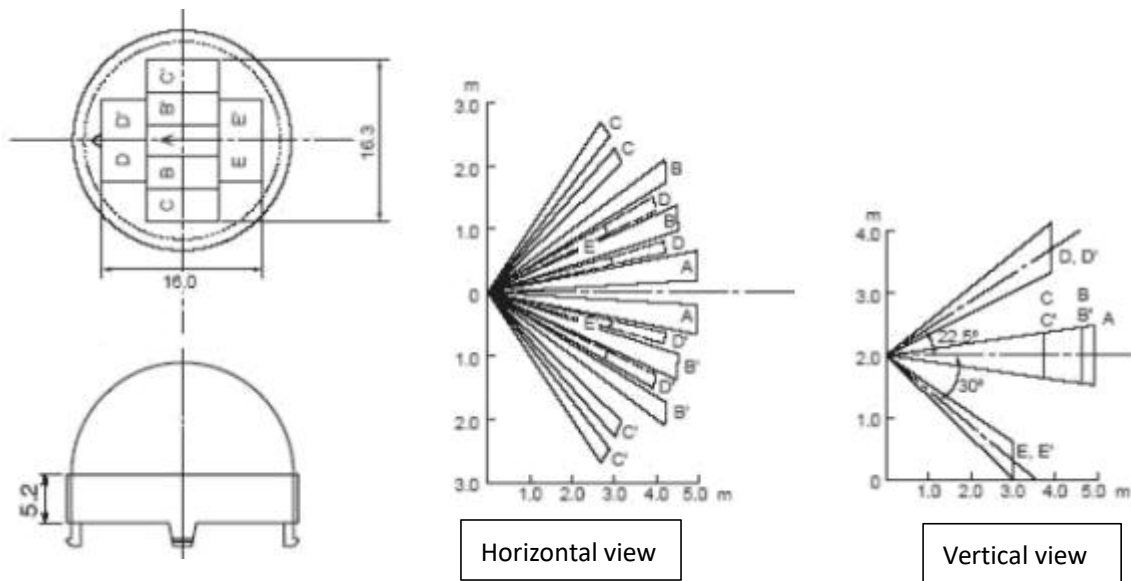

Typical application circuit:

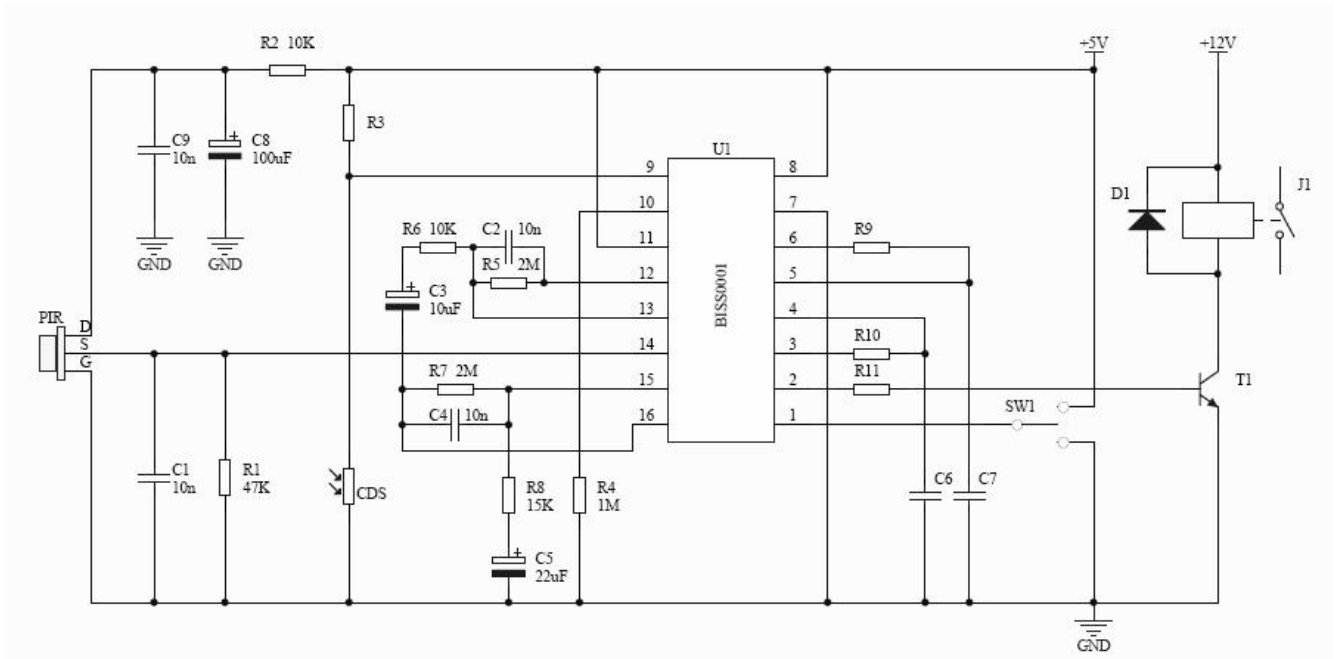

Note: R9, R10, C6, and C7 can be adjusted based on actual needs.

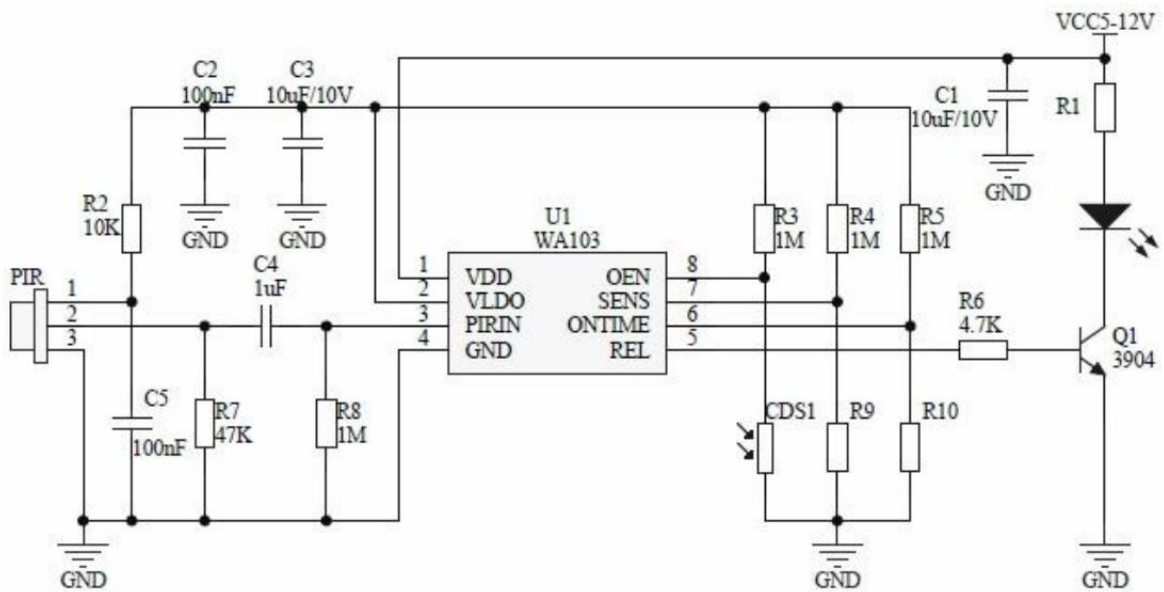

Note: R9, and R10 can be adjusted based on actual needs.

The receiving wavelength of the window material:

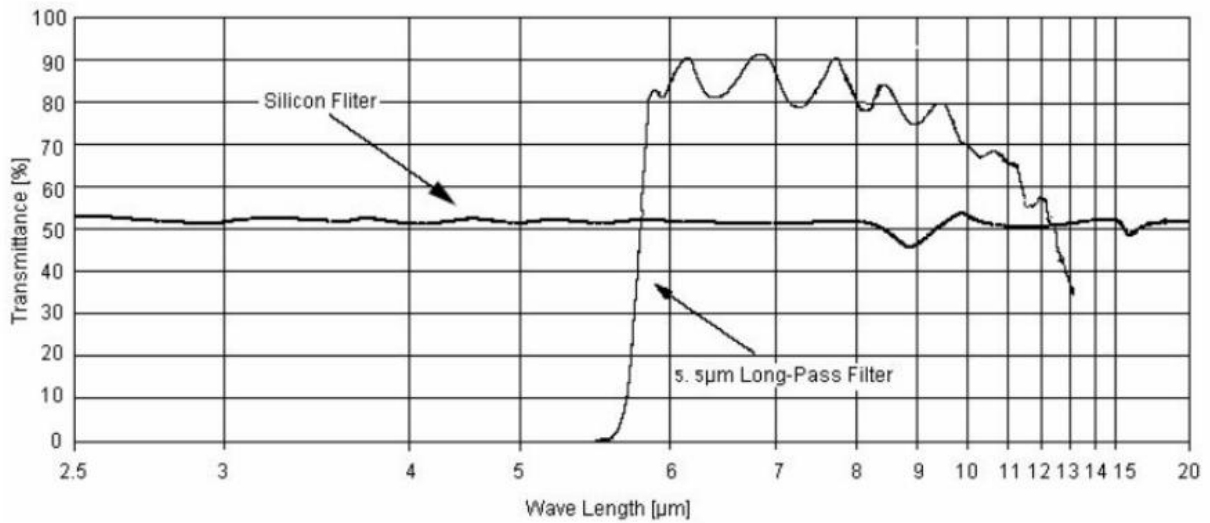

Note: This chart is typical 5um infrared filter, and the curve is the average value of infrared pass rate. This window material is a semiconductor wafer, which is processed by special vacuum coating.

Reliability Test

Test Items	Test Conditions	Criteria
High Temperature	85°C, for 500 hours	<p>After reliability testing, place the sensors in room temperature condition for 3hours, then test them again:</p> <ol style="list-style-type: none"> Appearance: no remarkable damage Sensitivity: within 20% of initial sensitivity value (acceptable tolerance) Noise: +100mV of initial value (max tolerance)
Low Temperature	-40°C, for 500 hours	
Humidity	60°C, 95%RH, for 500 hours	
High Temperature Loading	85°C, 5V applied, 47K load, for 48 hours	
Heat Shock	-10°C, 30min ← → 50°C, 30min*10 cycles	
Anti-static	200p F, 0Ω, 200V	
Vibration	Apply vibration of amplitude of 1.5mm with 10 to 55Hz to each of 3 perpendicular directions for 60min	
Lead Strength	1kg strain force along lead, 5sec	
Drop Test	Dropping from 750mm high, 3 times	
Soldering Heat	260±5°C, 10±1sec, dipping leads submerge into solder down to 3.0mm below stem	
Hermetic Seal	125±5°C FC-40, 20min	No bubble visible

Cautions:

1. The sensor's parameter is obtained by standard testing condition after 1 minute's settling time.
2. Please pay attention on Sensor's window direction, must combine with Fresnel lens to get a perfect detecting angle.
3. Sensors detecting distance is affected by ambient temperature, moving objects' temperature, Fresnel lens, Amplifier amplification factor, the comparator threshold voltage setting...etc. please take a comprehensive consideration of various parameters when using the sensors.
4. Please do not touch the window area to avoid damaging to the optical filter.
5. Please handle the sensor with care when using it.
6. Please add Rc filter circuit to the sensor's power supply side when design the circuits.(please take typical application circuits for R2,C8 and C9 as reference)
7. Please try to use hand soldering and make the soldering time as short as possible.
8. Please get electrostatic protective measures when using this product.

Note: To keep continual product development, we reserve the right to change design features without prior notice.

Zhengzhou Winsen Electronics Technology Co., Ltd

Add: No.299, Jinsuo Road, National Hi-Tech Zone,
Zhengzhou 450001 China

Tel: +86-371-67169097/67169670

Fax: +86-371-60932988

E-mail: sales@winsensor.com

Website: www.winsen-sensor.com