



# **Digital Pyroelectric Infrared Sensor (Model: RDB224)**

## **User's Manual**

Version: 1.0

Valid from: 2019-11-25

Zhengzhou Winsen Electronics Technology Co., Ltd

# Statement

This manual copyright belongs to Zhengzhou Winsen Electronics Technology Co., LTD. Without the written permission, any part of this manual shall not be copied, translated, stored in database or retrieval system, also can't spread through electronic, copying, record ways.

Thanks for purchasing our product. In order to let customers use it better and reduce the faults caused by misuse, please read the manual carefully and operate it correctly in accordance with the instructions. If users disobey the terms or remove, disassemble, change the components inside of the sensor, we shall not be responsible for the loss.

The specific such as color, appearance, sizes &etc, please in kind prevail.

We are devoting ourselves to products development and technical innovation, so we reserve the right to improve the products without notice. Please confirm it is the valid version before using this manual. At the same time, users' comments on optimized using way are welcome.

Please keep the manual properly, in order to get help if you have questions during the usage in the future.

**Zhengzhou Winsen Electronics Technology CO., LTD.**

## RDB224 Digital Pyroelectric Infrared Sensor

Digital PIR sensor RDB224, is an integrated design of sensitive element and signal processing chip, packaged sensitive element and IC chip into sensor shield. Sensitive element transfer the human movement signal to high-precision digital chip for data processing. Then the sensor gives digital signal for easy using.

### Features:

- \* High-precision AD signal process
- \* Differential signal input mode, anti-interference ability
- \* Delay time adjustment function
- \* Wide voltage power supply(1.5~4.5V) and power consumption
- \* Digital TTL signal output



### Applications

Security product  
Human body induction toys  
Human body induction lamps, and switches  
Industrial automation control  
Smart home  
IOT terminals  
Intelligent appliance

### Technical Parameter

#### 1. Max Limit

Parameter	Symbol	Min	Max	Unit	Note
Voltage	V <sub>DD</sub>	-0.3	4.5	V	25℃
Pin Voltage		-0.3	V <sub>DD</sub> +0.3	V	25℃
Storage temperature	T <sub>ST</sub>	-40	125	℃	

#### 2. Working condition(T=25℃)

Parameter	Symbol	Min	Typical	Max	Unit	Note
Working condition						
Voltage	V <sub>DD</sub>	1.5	3.0	4.5	V	Power supply mode
Current	I <sub>DD</sub>		10		uA	10uA @3V@25℃
Sensitivity	V <sub>SENS</sub>		104		uV	
Temperature	W <sub>ST</sub>	-25		85	℃	
ONTIME Pin						
ONTIME Input Range		0		V <sub>DD</sub>		
ONTIME Input Current	V <sub>IL</sub>			20	nA	Pull-down current
Output Pin(REL)						
Output drive current	I <sub>REL</sub>	-5		5	mA	
Block time			2.0		S	
Delay time	ON <sub>TIME</sub>	1.0		3600	S	16 levels of adjustment
Oscillators and filters						
Low filter cut-off				7	Hz	

frequency						
High filter cut-off frequency				0.4	Hz	
Chip oscillator frequency	F <sub>CLK</sub>			32	KHz	
Chip oscillator error	F <sub>CLK_Err</sub>	-1000		1000	Ppm/K	-20~80°C

### 3. Internal frame

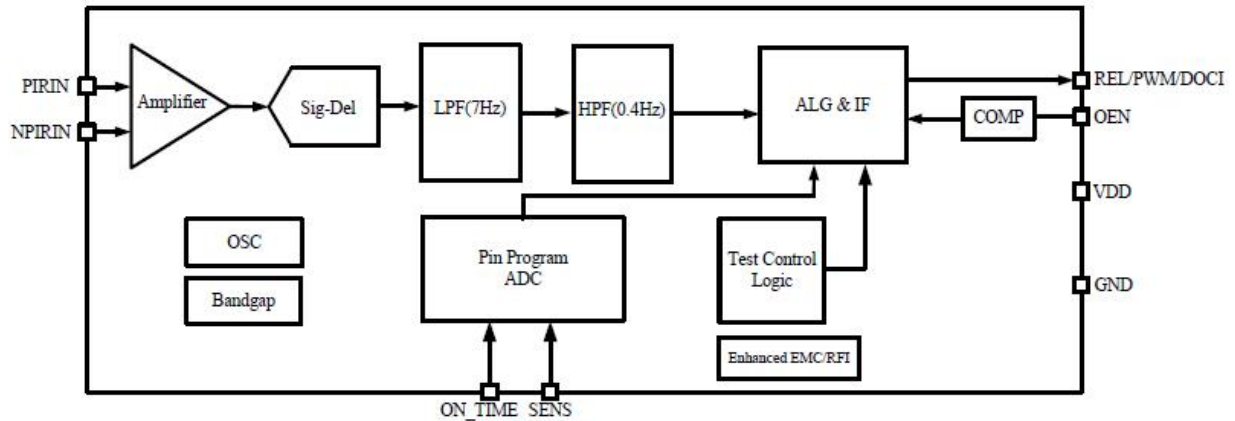

### 4. Trigger mode

In the normal detection condition, the following two conditions are valid:

- (1) When the signal amplitude successively exceeds the positive and negative thresholds within 4S ;
- (2) The signal amplitude exceeds 5 times the threshold;

After the sensor is effectively triggered, the REL pin gives output and maintains a high level for a certain period of time. The output high level time can be adjusted by the voltage divider resistor of the ONTIME pin. During the high level output period, if the effective trigger signal is detected again, the output high time is recalculated.

Remark: The sensor has warm-up time. After power on, the REL pin outputs high level for 10 seconds and low level for 2 seconds. Warm-up time has nothing to do with ONTIME

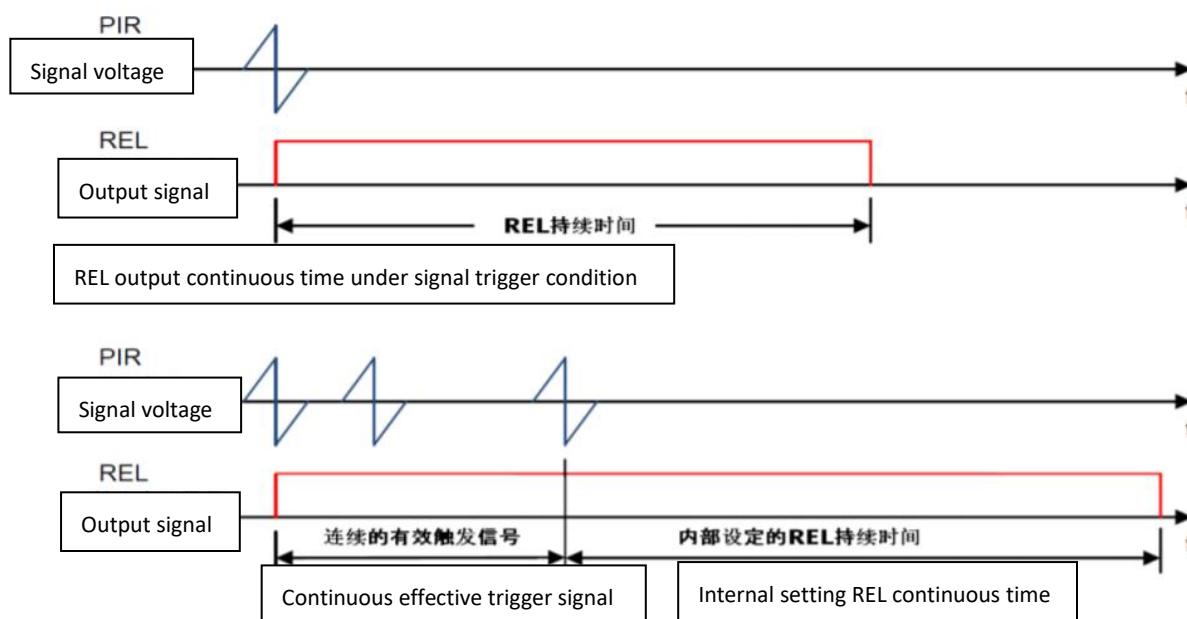

Note: If the trigger signal is detected again within the duration, the duration will be recalculated.

### 5. Delay time adjustment

The delay time is the high-level TTL output duration time when sensor reaches the comparison threshold. The input voltage of ONTIME pin, determines the duration of output signal. Each time a trigger signal is received, the delay time is recalculated.

Relationship between ONTIME pin voltage, delay time and voltage divider resistance:

Item	Corresponding pin voltage range	Center value of Pin voltage	Duration time (Second)	Pull-up resistor (ohm)	Theoretical pull-down resistor(ohm)	Recommended pull-down resistor(ohm)
1	$(0 \sim 8/256) * VDD$	$1 * VDD/64$	1	1M	16k	GND
2	$(9/256 \sim 16/256) * VDD$	$3 * VDD/64$	5	1M	49k	47k
3	$(17/256 \sim 24/256) * VDD$	$5 * VDD/64$	10	1M	85k	82k
4	$(25/256 \sim 32/256) * VDD$	$7 * VDD/64$	15	1M	122k	120k
5	$(33/256 \sim 40/256) * VDD$	$9 * VDD/64$	20	1M	164k	160k
6	$(41/256 \sim 48/256) * VDD$	$11 * VDD/64$	30	1M	208k	205k
7	$(49/256 \sim 56/256) * VDD$	$13 * VDD/64$	45	1M	255k	261k
8	$(57/256 \sim 64/256) * VDD$	$15 * VDD/64$	60	1M	306k	300k
9	$(65/256 \sim 72/256) * VDD$	$17 * VDD/64$	90	1M	362k	360k
10	$(73/256 \sim 80/256) * VDD$	$19 * VDD/64$	120	1M	422k	430k
11	$(81/256 \sim 88/256) * VDD$	$21 * VDD/64$	180	1M	488k	487k
12	$(89/256 \sim 96/256) * VDD$	$23 * VDD/64$	300	1M	561k	560k
13	$(97/256 \sim 104/256) * VDD$	$25 * VDD/64$	600	1M	641k	620k
14	$(105/256 \sim 112/256) * VDD$	$27 * VDD/64$	900	1M	730k	750k
15	$(113/256 \sim 120/256) * VDD$	$29 * VDD/64$	1800	1M	829k	820k
16	$(121/256 \sim 128/256) * VDD$	$31 * VDD/64$	3600	1M	940k	1M

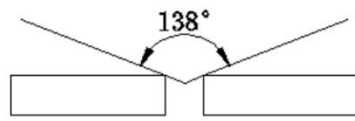
**Sensor Detection Angle**

X-X

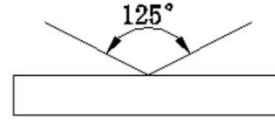

Y-Y

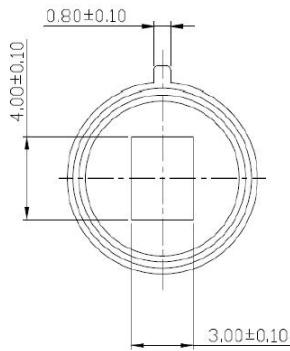
**Component Structure (Unit: mm)**

Top view

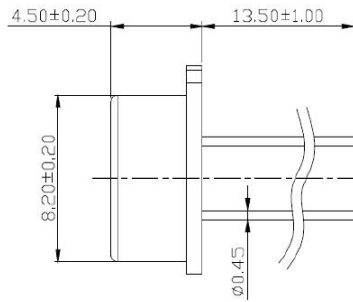

Side view

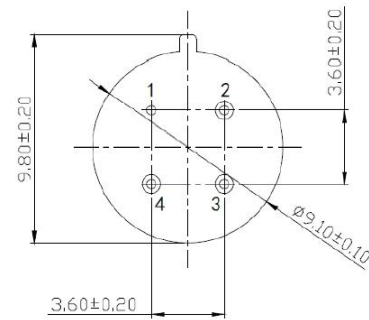

Bottom view

**Pin Definition**

Item	Name	Definition
1	VSS	power ground
2	ONTime	delay time adjustment pin, 16 level option, the delay time is recalculated after each trigger
3	VDD	sensor power supply pin
4	REL	sensor output pin, TTL high/low level output
Note		Select 0, it's recommended using a resistor to pull down to ground. Select high level, it's recommended pulling up to high level with resistor.

### Frequency characteristic

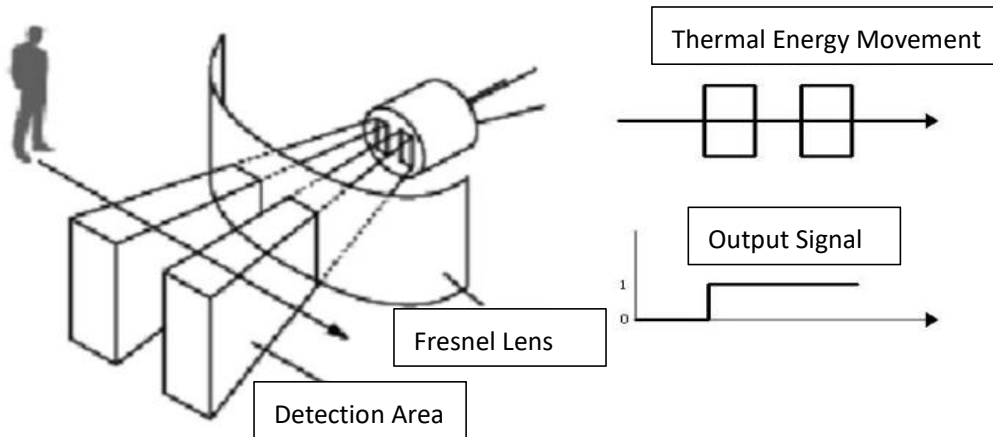

### Fresnel Lens:

Fresnel Lens used, would determine the sensor's detection angle and distance, which can correspond to a variety of detection range and distance, according to customers' requirement.

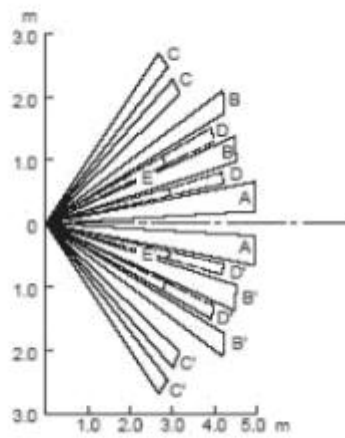
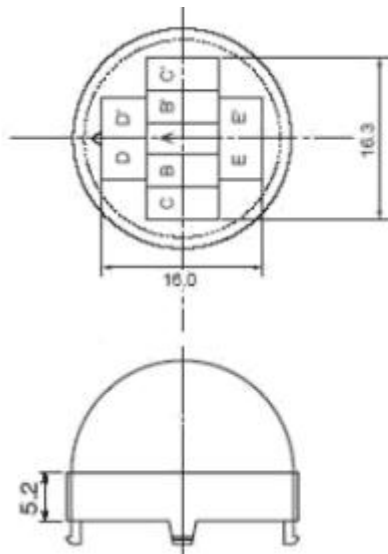

Horizontal Field of View

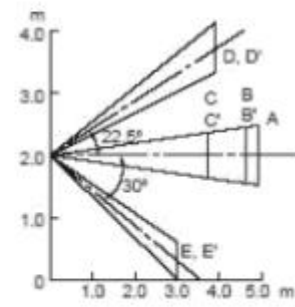

Vertical Field of View

## Wave Length

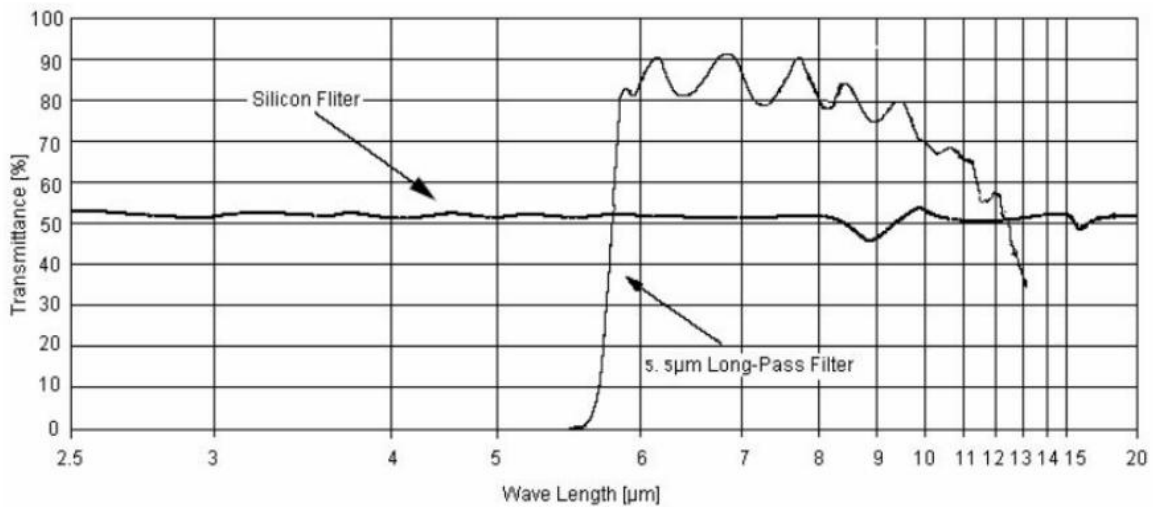

Note: The graph shows a typical 5um infrared filter reference, and the curve is the average of infrared pass rate. The window material is a special vacuum coating of semiconductor wafers.

## Typical Application circuit

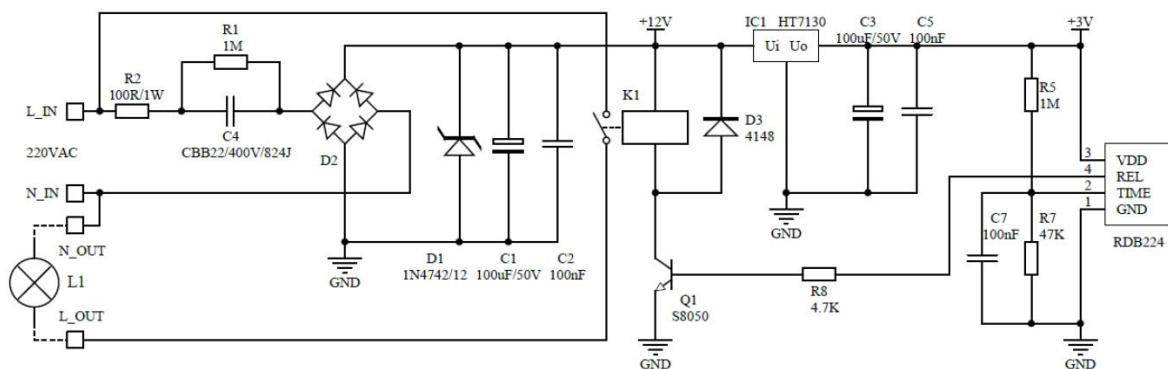

## Cautions:

1. The sensor's parameter is obtained by standard testing condition after 1 minute's settling time.
2. Please pay attention on Sensor's window direction, must combine with Fresnel lens to get a perfect detecting angle.
3. Sensors detecting distance is affected by ambient temperature, moving objects' temperature, Fresnel lens, Amplifier amplification factor, the comparator threshold voltage setting...etc. please take a comprehensive consideration of various parameters when using the sensors.
4. Please do not touch the window area to avoid damaging to the optical filter.
5. Please handle the sensor with care when using it.
6. Please try to use hand soldering and make the soldering time as short as possible. Soldering temperature should be less than 300°C, and soldering time be less than 3 seconds.



7. Please get electrostatic protective measures when using this product, as applying static electricity of  $\pm 800V$  or more may damage the sensor.

**Note:** To keep continual product development, we reserve the right to change design features without prior notice.

**Zhengzhou Winsen Electronics Technology Co., Ltd**

**Add:** No.299, Jinsuo Road, National Hi-Tech Zone,  
Zhengzhou 450001 China

**Tel:** +86-371-67169097/67169670

**Fax:** +86-371-60932988

**E-mail:** [sales@winsensor.com](mailto:sales@winsensor.com)

**Website:** [www.winsen-sensor.com](http://www.winsen-sensor.com)