



# Ultrasonic Oxygen Sensor (Model: US1000)

## User's Manual

(Version 1.0)

Issue Date: 2022.09.30

Zhengzhou Winsen Electronics Technology Co., Ltd  
ISO9001 Certificated Company

## Statement

This manual's copyright belongs to Zhengzhou Winsen Electronics Technology Co., LTD. Without the written permission, any part of this manual shall not be copied, translated, stored in database or retrieval system, also can't spread through electronic, copying, record ways.

Thanks for purchasing our product. In order to let customers use it better and reduce the faults caused by misuse, please read the manual carefully and operate it correctly in accordance with the instructions. If users disobey the terms or remove, disassemble, change the components inside of the sensor, we shall not be responsible for the loss.

The specific such as color, appearance, sizes &etc., please in kind prevail.

We are devoting ourselves to products development and technical innovation, so we reserve the right to improve the products without notice. Please confirm it is the valid version before using this manual. At the same time, users' comments on optimized using way are welcome.

Please keep the manual properly, in order to get help if you have questions during the usage in the future.

**Zhengzhou Winsen Electronics Technology CO., LTD.**

---

Email: [sales@winsentech.com](mailto:sales@winsentech.com)

**Leading gas sensing solutions supplier in China!**

## US1000 Ultrasonic Oxygen Sensor

### Profile

The US1000 ultrasonic oxygen sensor is mainly used in the detection of oxygen concentration and flow in oxygen concentrators and related products. It uses ultrasonic sensors to detect the propagation speed of ultrasonic waves in gas, and uses temperature compensation to accurately calculate oxygen concentration and flow.



### Main Features

- \*Good consistency
- \*Real-time response
- \*High precision
- \*Good stability
- \*long lifespan
- \*Calibration-free

### Applications

- \*Household oxygen generator
- \*Medical oxygen concentrator

### Detection principle

The propagation time of ultrasonic waves in a binary gas mixture changes with the concentration and flow of the two gases. According to this law, the gas concentration and flow velocity can be calculated at the same time without affecting the normal flow of the gas.

Model No.		US1000
Detection method		ultrasound
Detection gas		O <sub>2</sub>
Concentration	Measuring range	21% ~ 95.6%
	Measurement accuracy	± 1.5%FS @(5 ~ 45)°C
	Resolution	0.1%
	Response time	≤15s T90 (Can be customized according to customer requirements, the fastest ≤1s )
Flow	Measuring range	0 ~ 10L/min
	Measurement accuracy	±0.2L/min@(5 ~ 45)°C
	Resolution	0.1L/min
	Response time	≤15s T90 (Can be customized according to customer requirements, the fastest ≤1s )
Working voltage		4.5 ~ 13.2V
Average current		≤30mA
Working environment		0 ~ 55°C; 0 ~ 95%RH ( no condensation )
Storage environment		-30 ~ 65°C; 0 ~ 95%RH ( no condensation )
Output signal		UART(3.3V)
Dimensions		120mm*30mm*30mm(L*W*H)
Weight		25g
Lifespan		≥5 years

**Table 1 - Technical Specifications**

**Pin sequence:**

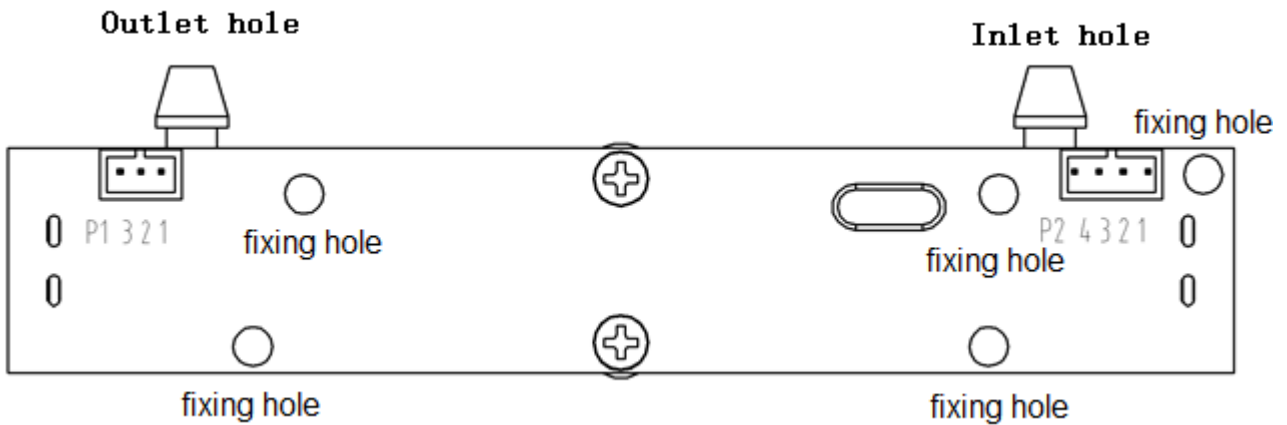

**Figure 1 - Pin sequence**

Terminal description: P1 model is PH2.0-3P (Spacing 2.0mm), P2 model is PH2.0-4P (Spacing 2.0mm).

**Pin definition:**

**Table 2 - Pin Definition**

Pin name	Pin description
P1-1	VCC(4.5 ~ 13.2V)
P1-2	NC dangling
P1-3	GND
P2-1	VCC(4.5 ~ 13.2V)
P2-2	UART(RXD) Serial port receiving (3.3V ~ 5V)
P2-3	UART(TXD) Serial sending (3.3V)
P2-4	GND

**Communication Description:**

**1. Hardware connection**

Connect the VCC-RXD-TXD-GND of the sensor to the VCC-TXD-RXD-GND of the customer respectively, as shown in the figure below (the user side needs to use TTL level, if it is RS232 level, it must be converted).

A typical interface circuit is as follows:

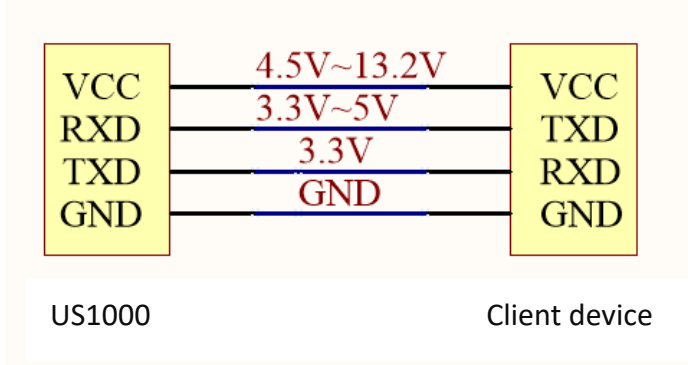

**2. Serial parameters**

**Table 3 - Serial port configuration**

name	description
Baud rate	9600
Data bit	8 bits
stop bit	1 bit
Check digit	None

**3. Protocol Description**

start byte	length	order	data	checksum
Head	Length	Command	Data	Checksum
1Byte	1Byte	1Byte	nByte	1Byte

Data shows:

Note: 1. The data are all hexadecimal data, 1Byte refers to single-byte unsigned number (0-255), nByte refers to n-byte unsigned number;

The high byte of double-byte data comes first, and the low byte follows.

Data name	Illustrate
Start byte	The upper computer send is fixed at 0x11, and the sensor module response is fixed at 0x16
Length	= command length (1) + data length (n) (note: data length n can be 0)
Order	The sensor executes the command, 0x01 is to read the oxygen data measured by the sensor, and the rest are reserved.

Data	The data sent by the host or the sensor, the length is n bytes, or there is no data (n=0)
Checksum	$=(0xFF - (\text{Head} + \text{Length} + \text{Command} + \text{Data}))+1$ (Note: checksum = all values except the checksum are accumulated and inverted + 1)

#### 4. Example

	start byte	length	order	check value
host sends	11	01	01	ED

	start byte	length	order	data (D1)	data (D2)	data (D3)	data (D4)	data (D5)	data (D6)	data (D7)	data (D8)	check value
sensor send	16	09	01	03	A7	00	0C	01	1B	00	00	0E

Note:

The sensor has two data output modes. In the response mode, it is recommended that the host send the interval not less than 0.5S, and the active upload mode of the sensor is to send a set of data in 1S.

#### Function:

Read O<sub>2</sub> measurement results

#### Data analysis:

D1 and D2 are concentration values, O<sub>2</sub> concentration value =  $(D1*256 + D2)/10$  (Vol %)

D3 and D4 are flow values, O<sub>2</sub> flow value =  $(D3*256 + D4)/10$  (L/min)

D5 and D6 are temperature values, O<sub>2</sub> temperature value =  $(D5*256 + D6)/10$  (°C)

(Note: The temperature returned by the sensor is the temperature of the gas in the sensor chamber)

D7 and D8 are reserved data

#### Example calculation results:

Each value is hexadecimal data, it should be converted to decimal number when calculating

D1=0x03=3, D2=0xA7=167, O<sub>2</sub> concentration value= $(3*256+167)/10=93.5\%$

D3=0x00=0, D4=0x0C=12, O<sub>2</sub> flow value= $(0*256+12)/10=1.2L/min$

$D5=0 \times 01=1$ ,  $D6=0 \times 1B=27$ ,  $O_2$  temperature value  $= (1 \times 256 + 27) / 10 = 28.3 \text{ }^\circ\text{C}$

**Notes:**

- When the sensor is installed and used, it is forbidden to touch the pins of the transducers at both ends of the sensor;
- Do not disassemble the sensor gas pipeline fixing screws at will;
- The air inlet and outlet holes of the sensor must not be blocked or polluted, and liquids and debris are prohibited from entering the sensor gas pipeline;
- The sensor should not be subject to excessive impact or vibration;
- Do not use if the shell is damaged or deformed;

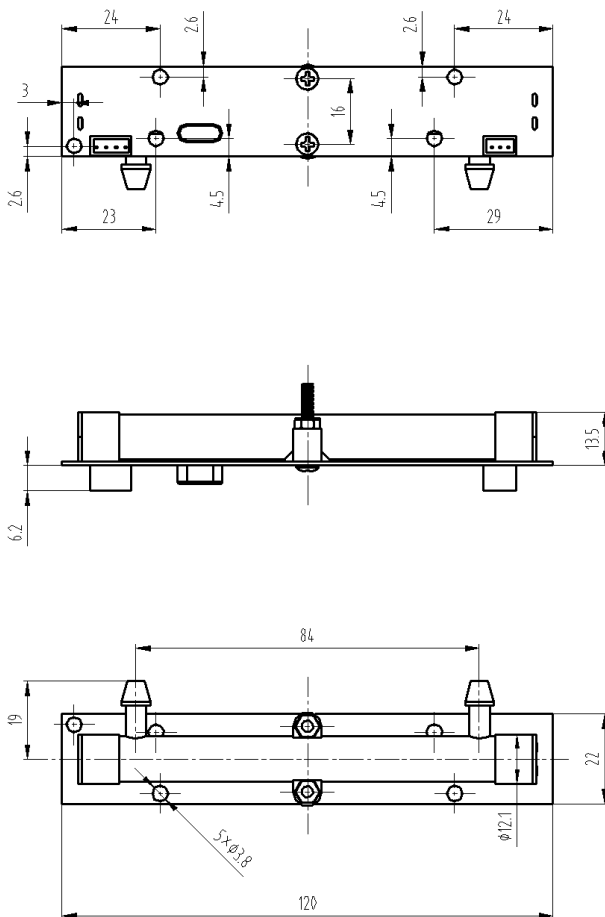
**Product Size**

Unnoted tolerance is  $\pm 0.3\text{mm}$

**Zhengzhou Winsen Electronics Technology Co., Ltd**

**Add:** No.299, Jinsuo Road, National Hi-Tech Zone,  
Zhengzhou 450001 China

**E-mail:** [sales@winsentech.com](mailto:sales@winsentech.com)

**Website:** [www.winsentech.com](http://www.winsentech.com)

Email: [sales@winsentech.com](mailto:sales@winsentech.com)

**Leading gas sensing solutions supplier in China!**