



Malodorous Gases Sensor Module

(Model: ZE809-0U)

User's Manual

Version: 1.2

Issue Date: 2023-05-06

Zhengzhou Winsen Electronic Technology Co., Ltd

Statement

This manual's copyright belongs to Zhengzhou Winsen Electronics Technology Co., LTD. Without the written permission, any part of this manual shall not be copied, translated, stored in database or retrieval system, also can't spread through electronic, copying, record ways.

Thanks for purchasing our product. In order to let customers use it better and reduce the faults caused by misuse, please read the manual carefully and operate it correctly in accordance with the instructions. If users disobey the terms or remove, disassemble, change the components inside of the sensor, we shall not be responsible for the loss.

The specific such as color, appearance, sizes &etc., please in kind prevail.

We are devoting ourselves to products development and technical innovation, so we reserve the right to improve the products without notice. Please confirm it is the valid version before using this manual. At the same time, users' comments on optimized using way are welcomed.

Please keep the manual properly, in order to get help if you have questions during the usage in the Future.

Zhengzhou Winsen Electronics Technology CO., LTD

ZE809-OU Malodorous Gases Sensor Module

Description

ZE809-OU Malodorous Gases Sensor Module uses high-precision electrochemical sensors, specialized instrument amplifiers, high-precision processors, and intelligent algorithms to convert the detected ammonia gas concentration into recognizable digital signals, which are transmitted through serial ports. Convenient for users to use and debug, shortening their design and development cycle.

The module is equipped with sensors with good linearity, high precision, high sensitivity, strong anti-interference ability, excellent repeatability and stability, and combined with temperature and humidity compensation algorithms, greatly improving the reliability of the module.



Natural diffusion type

Integrated pump type

Characteristic

- Small size
- Dual signal output (UART signal, analog voltage signal)
- High stability, high anti-interference
- Temperature and humidity compensation
- Sampling method can be selected: natural diffusion or integrated pumping

Application

Mainly used in gas monitoring, Internet of Things, UAV, atmospheric environment monitoring instrument, micro air quality monitoring station, toxic gas detection and other fields.

Technical Data

Sheet 1

Model No.	ZE809-OU
Detection Gas	Stench, odor
Detection Range	0~100 OU
Working voltage	DC 5±0.1V
Working Current	≤80mA
Output Signal	UART(TTL Level 3.3 V), Analog signal (0-5V)
Accuracy	≤±5%
Repeatability	≤±3%

Picture 1: Module side and bottom views

Note: Error: ±0.25mm

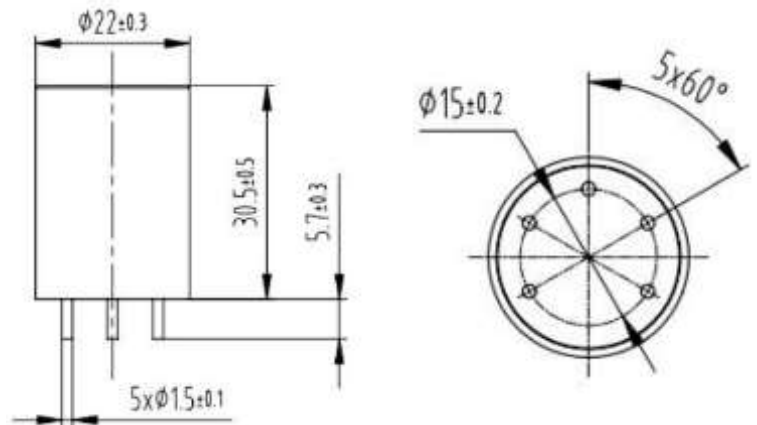

Response Time	T90≤30s
Preheat Time	30s
Resolution	0.1 OU
Working Environment	Temperature: -20~50°C, Humidity: 15%~93%RH No condensation
Storage Environment	Temperature: -20~60°C, Humidity: 15%~75%RH
Dimension	Φ22mm * 30.5mm

Picture 2: Tube base dimension for module matching

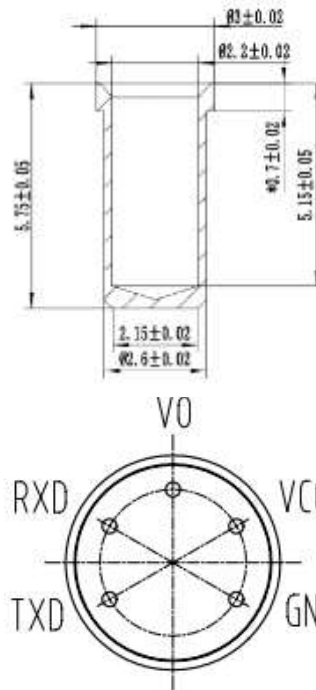

Pin definition

Picture 2

GND	Power Ground
VCC	Voltage supply
VO	Analog signal
RXD	Serial port input
TXD	Serial port output

Note

1. After long-term storage, the module needs to be energized for a longer time to achieve stability before use, and the module needs to be aged for at least 24 hours for the first time.
2. Direct welding of the pins of the module is prohibited. The tube seat of the pins can be welded, and the size of the tube seat is shown in Figure 2.
3. The module can not withstand excessive impact or vibration.
4. Do not apply this module to the system involving personal safety.
5. Do not install the module in strong air convection environment.
6. To determine whether the module communication is normal, it is recommended to use the USB to TTL tool (communication level 3.3V), observe and judge according to the communication protocol through the serial debugging assistant software.

Zhengzhou Winsen Electronics Technology Co., Ltd

Add: No.299, Jinsuo Road, National Hi-Tech Zone, Zhengzhou 450001 China

Tel: +86-371-67169097/67169670

Fax: +86-371-60932988

E-mail: sales@winsensor.com

Website: www.winsen-sensor.com

