



Vehicle-Mounted Fuel Gas
Leakage Detection Module
(Model:ZP10)

Manual

Version: 1.6

Valid From: 2014.08.08

Zhengzhou Winsen Electronics Technology Co., Ltd

Statement

This manual copyright belongs to Zhengzhou Winsen Electronics Technology Co., LTD. Without the written permission, any part of this manual shall not be copied, translated, stored in database or retrieval system, also can't spread through electronic, copying, record ways.

Thanks for purchasing our product. In order to let customers use it better and reduce the faults caused by misuse, please read the manual carefully and operate it correctly in accordance with the instructions. If users disobey the terms or remove, disassemble, change the components inside of the sensor, we shall not be responsible for the loss.

The specific such as color, appearance, sizes &etc, please in kind prevail.

We are devoting ourselves to products development and technical innovation, so we reserve the right to improve the products without notice. Please confirm it is the valid version before using this manual. At the same time, users' comments on optimized using way are welcome.

Please keep the manual properly, in order to get help if you have questions during the usage in the future.

Zhengzhou Winsen Electronics Technology CO., LTD

ZP10 Vehicle-Mounted Fuel Gas Leakage Detection Module

Profile

ZP10 adopts vehicle-mounted semiconductor sensor and vehicle-mounted micro-processor, which assure the testing accuracy, and meet the strict temperature requirement in the vehicle. It is specific designed for fuel gas leak alarm. The below black base uses automotive-specific socket, with dedicated waterproof harness connector. There are two kinds of controller as supporting, Z101 and Z102. Every controller can connect with to probes, connecting to the engine and cylinder position through vehicle-mounted harness. It will detect leakage all the moments to protect driving safety.



Features

High sensitivity, wide voltage input, strong anti-jamming capability, good stability and shock resistance

Applications

It is widely used for complete device development of vehicle-mounted flue gas leak alarm and combustible gas detection in the vehicle.

Technical Parameters Stable1

Model	ZP10
Detection Gas	Natural gas, LPG, Manufactured Gas
Detection range	1~25%LEL
Response Time	< 30s
Resume Time	< 30s
Working Voltage	DC 6~42V
Working Current	< 80mA
Output	1 Single Output
Accuracy	±4%LEL(under room temperature)
Expected Life	> 1 year
Working Environment	Temperature: -20~85°C
	Humidity: 20%~90%RH
Storage Environment	Temperature: -20~70°C
	Humidity: 20%~90%RH
Size	Φ23×60.5mm

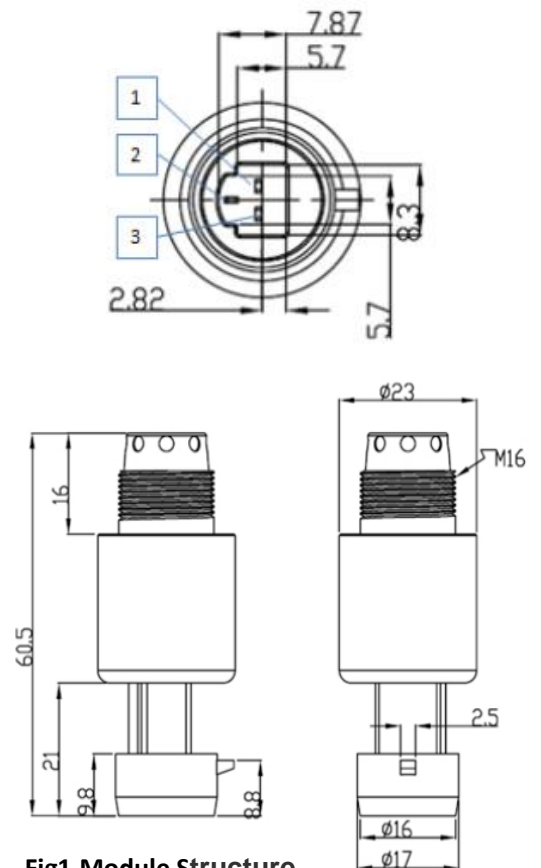
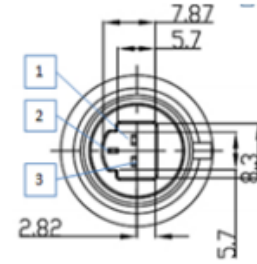

Fig1.Module Structure

Pins Definition Stable 2.

PIN1	GND
PIN2	Output Signal
PIN3	VCC



S is the state output for the module:

In normal working state: Output is 5KHz wave, which occupies 20% ratio.

In failure state: Output is 5KHz wave, which occupies 80% ratio.

In alarm state: Output is 5KHz wave which occupies 50% ratio

Cautions**1 .Following conditions must be prohibited****1.1 Exposed to organic silicon steam**

Module will lose sensitivity and never recover if it absorbs organic silicon steam. Module must avoid exposing to silicon bond, fixture, silicon latex, putty or plastic contain silicon environment.

1.2 High Corrosive gas

If the module is exposed to high concentration corrosive gas (such as H₂S, SO_x, Cl₂, HCl etc.), it will not only result in corrosion of sensor's heating material and pins, also it causes sensitivity and performance attenuation.

1.3 Touch water

Sensitivity of the sensors will be reduced when spattered or dipped in water.

1.4 Freezing

Do avoid icing on sensor's surface, otherwise sensing material will be broken and lost sensitivity.

2 .Following conditions must be avoided**2.1 Water Condensation**

Indoor conditions, slight water condensation will influence sensors' performance lightly. However, if water condensation stay on sensing material surface and keep a certain period, sensors' sensitive will decrease.

2.2 Used in high gas concentration

No matter the sensor is electrified or not, if it is placed in high gas concentration for long time, sensors characteristic will be affected. If lighter gas sprays the sensor, it will cause extremely damage.

2.3 Long time storage

The sensors resistance will drift reversibly if the module is stored for long time without electrify, this drift is related with storage conditions. Modules should be stored in airproof bag without volatile silicon compound. For the modules with long time storage but no electrify, they need long galvanical aging time for stability before using. The suggested aging time as follow:

Stable3.

Storage Time	Suggested aging time
Less than one month	No less than 48 hours
1 ~ 6 months	No less than 72 hours
More than six months	No less than 168 hours

2.4 Long time exposed to adverse environment

No matter the modules electrified or not, if exposed to adverse environment for long time, such as high humidity, high temperature, or high pollution etc., it will influence the module's performance badly.

Zhengzhou Winsen Electronics Technology Co., Ltd

Add: No.299, Jinsuo Road, National Hi-Tech Zone,
Zhengzhou 450001 China

Tel: +86-371-67169097/67169670

Fax: +86-371-60932988

E-mail: sales@winsensor.com

Website: www.winsen-sensor.com