



# NDIR Infrared CH4 Gas Sensor

(Model: MH-441D)

# Manual

Version: 1.0

Valid from: 2020.09.14

Zhengzhou Winsen Electronics Technology Co., Ltd

# Statement

This manual copyright belongs to Zhengzhou Winsen Electronics Technology Co., LTD. Without the written permission, any part of this manual shall not be copied, translated, stored in database or retrieval system, also can't spread through electronic, copying, record ways.

Thanks for purchasing our product. In order to let customers use it better and reduce the faults caused by misuse, please read the manual carefully and operate it correctly in accordance with the instructions. If users disobey the terms or remove, disassemble, change the components inside of the sensor, we shall not be responsible for the loss.

The specific such as color, appearance, sizes &etc, please in kind prevail.

We are devoting ourselves to products development and technical innovation, so we reserve the right to improve the products without notice. Please confirm it is the valid version before using this manual. At the same time, users' comments on optimized using way are welcome.

Please keep the manual properly, in order to get help if you have questions during the usage in the future.

Zhengzhou Winsen Electronics Technology CO., LTD

## MH-441D NDIR Infrared CH4 Sensor

### 1. Introduction

MH-441D infrared gas sensor is a miniature universal intelligent sensor, which adopts NDIR theory to detect concentration of CH<sub>4</sub> in air and has good selectivity, stable performance, long life, also is independent of Oxygen. The inside temperature sensor could be used for temperature compensation. This miniature infrared gas sensor is developed by the tight integration of mature infrared absorbing gas detection technology, micro machine workout and superior circuit design.

It is convenient in use and also instead of catalytic component directly, widely used in various occasions with flammable and explosion hazard gas.



### 2.Features

- High sensitivity, high resolution, fast response
- Output method: UART, analog voltage signal
- Temperature compensation, excellent linear output
- Excellent stability, Long lifespan
- Anti-poisons, anti-vapor interference
- Can replace catalytic type gas sensor directly

### 3.Applications

Widely used for HVAC refrigeration, air monitoring indoor, industrial-process control and safety protection, agriculture and animal husbandry.

### 4.Main Parameters

Fig1.Technical Parameters

Detection Gas	Methane (CH <sub>4</sub> )
Working Voltage	3.6~5.0V DC (Need to be powered by safety barrier)
Average Current	<85mA
Interface Level	3.0V
Detection range	0~10%vol(selectable, refer fig2.)
Output Signal	UART(3.0V)
	0.4~2.0V DC
Warm-up time	3 min
Response time	T90<30 seconds
Working Temperature	-20°C ~ 60°C
Working Humidity	0~95%RH(no condensation)
Sizes	Φ 20 × 22.6mm
Weight	35g
Lifetime	>5 years
Defense Grade	IP54
Power, communication terminal Intrinsic safety	U <sub>i</sub> =7.5VDC, I <sub>i</sub> =265mA, P <sub>i</sub> =0.5W, C <sub>i</sub> =10 μ F, L <sub>i</sub> =0mH

Fig2.Measuring Range and Resolution

Target Gas	Molecular Formula	Measuring Range	Resolution	No. of decimal	Note
Methane	CH <sub>4</sub>	0~5.00%VOL	0.01%VOL	2	Temperature compensation
		0~10.00%VOL		2	
		0~100%LEL	1%LEL	none	

## 5. Struction Size

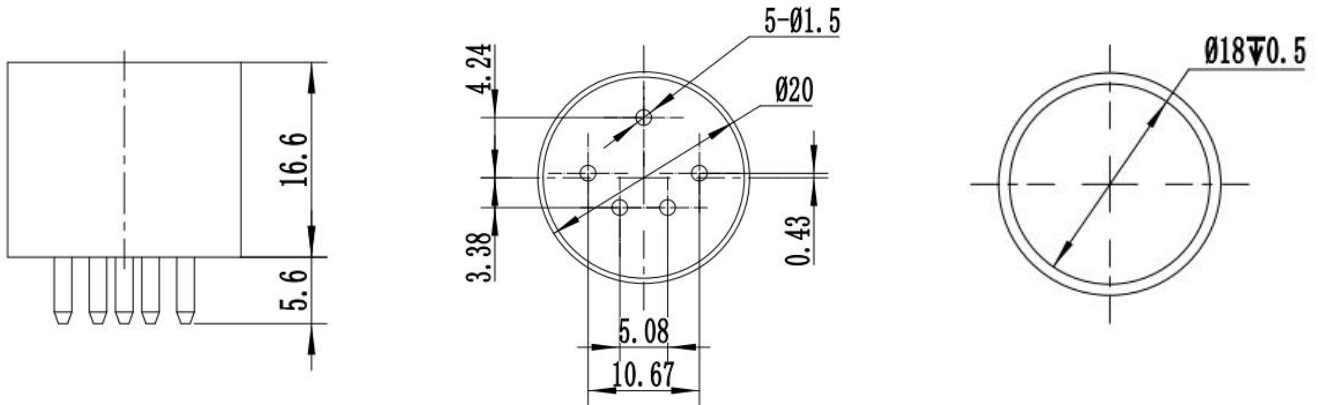

### ■ Pin definition

**Pin 2**-Vin power supply

**Pin 1**-GND

**Pin 4**-Vout (0.4~2V)

**Pin 3**-UART (RXD) 0~3.0V data input

**Pin 5**- UART (TXD) 0~3.0V data output

## 6. Output way.

### 6.1 Analog Output

The output of Vout is proportional to the gas concentration, 0.4-2.0V output stands for 0 to full range.

Connection: Vin -5V, GND- Power Ground, Vout-ADC input.

After warm-up, Vout will show the voltage standing for the gas concentration.

If self-checking detects a fault, the output voltage is 0V.

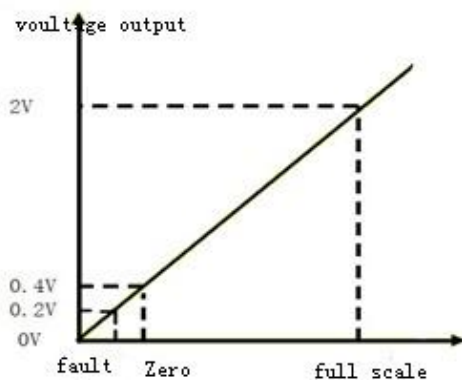

### 6.2 Digital Output

Please refer MH-441D communication protocol.

**Intrinsically safe explosion-proof**

- This product meets the standards of GB3836.1-2010 "Explosive Atmosphere Part 1: General Requirements for Equipment" and GB3836.4-2010 "Explosive Atmosphere Part 4: Equipment Protected by Intrinsically Safe "i" standards"; the explosion-proof mark is Exib II B T4 Gb, it is suitable for zone 1 and zone 2, contains Class IIA, T1-T3 explosive environment formed by the flammable gas, mixture of steam and air; it has passed the inspection by the National Quality Inspection Center for Explosion-proof Electrical Products and obtained the explosion-proof certificate. When using, please note the following:
  - The intrinsically safe power supply must be used to power the sensor, otherwise the explosion-proof performance will be affected.
  - It is forbidden to replace the sensor in dangerous places.
  - It is forbidden to disassemble or replace the sensor element to avoid affecting the explosion-proof performance.
  - It is not allowed to replace components or structures, so as not to affect the explosion-proof performance.
  - The installation and wiring of the safety barrier must be carried out in accordance with the safety barrier instruction manual, and the safety barrier must obtain an explosion-proof certificate.

**Connection diagram of intrinsically safe explosion-proof system**

The on-site installation must comply with the relevant regulations of the GB3836.15—2000 "Electrical Equipment for Explosive Gas Environment Part 15: Electrical Installation in Hazardous Locations (Except Coal and Mines).

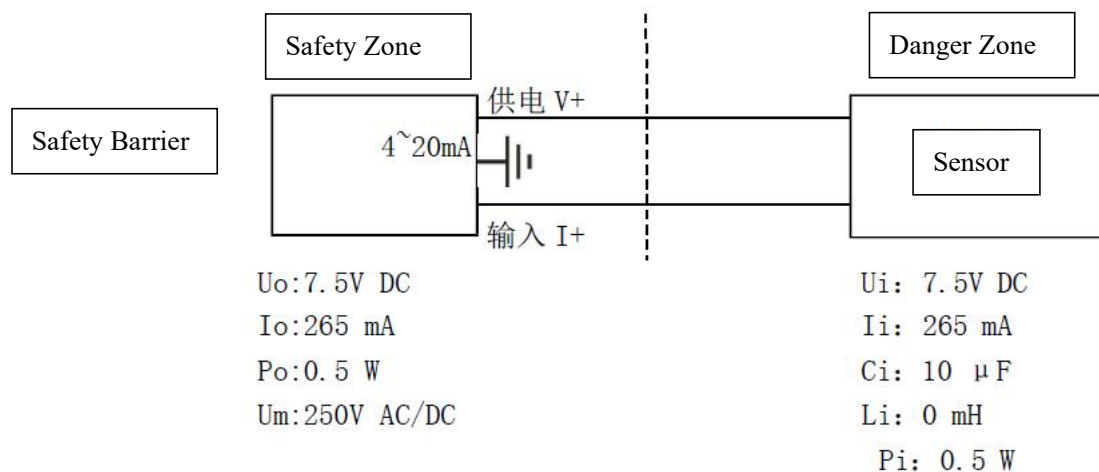

The distribution parameters of the connecting cable between the safety barrier and the sensor should meet:

$$C_c \leq C_o - C_i \quad L_c \leq L_o - L_i \quad U_i \geq U_o \quad I_i \geq I_o \quad P_i \geq P_o$$

**Note:**

U<sub>o</sub>: Maximum output voltage of safety barrier;

I<sub>o</sub>: Maximum output current of safety barrier

P<sub>o</sub>: Maximum output power of safety barrier

C<sub>o</sub>: Maximum external capacitance of safety barrier

L<sub>o</sub>: the maximum external inductance of the safety barrier (see the safety barrier instructions for the above parameters book)

C<sub>c</sub>: Maximum allowable distributed capacitance of connecting cable

U<sub>i</sub>: sensor maximum input voltage

I<sub>i</sub>: Maximum sensor input current

P<sub>i</sub>: sensor maximum input power

C<sub>i</sub>: Maximum internal capacitance of the sensor

Li: Maximum internal inductance of the sensor

Lc: Maximum allowable distributed inductance of connecting cable

## **7. Cautions for Maintenance**

- 7.1 The sensor should be calibrated regularly. The suggested cycle time is 6 months.
- 7.2 Do not use the sensor in the high dusty environment for long time.
- 7.3 Please use the sensor with correct power supply.
- 7.4 Forbid to weld the sensor pins directly.
- 7.5 Forbid to cut the sensor pins.