



# Methane Module for Home Use

(Model No.: ZC05)

# Manual

Version: V1.3

Issue Date:2019.01.25

Zhengzhou Winsen Electronics Technology Co., Ltd

# Statement

This manual copyright belongs to Zhengzhou Winsen Electronics Technology Co., LTD. Without the written permission, any part of this manual shall not be copied, translated, stored in database or retrieval system, also can't spread through electronic, copying, record ways.

Thanks for purchasing our product. In order to let customers use it better and reduce the faults caused by misuse, please read the manual carefully and operate it correctly in accordance with the instructions. If users disobey the terms or remove, disassemble, change the components inside of the sensor, we shall not be responsible for the loss.

The specific such as color, appearance, sizes &etc, please in kind prevail.

We are devoting ourselves to products development and technical innovation, so we reserve the right to improve the products without notice. Please confirm it is the valid version before using this manual. At the same time, users' comments on optimized using way are welcome.

Please keep the manual properly, in order to get help if you have questions during the usage in the future.

Zhengzhou Winsen Electronics Technology CO., LTD

## ZC05 Methane Module for Home Use

### Product Profile

This ZC05 Module adopts catalytic gas sensor and has basic function of home use gas leakage alarm with digital display: supplying digital UART signal and status indication, buzzer, relay, switch signal through solenoid valve output, as well as support alarm point resetting. It is usually used for development of home use natural gas leakage detector.



### Feature

- 1. Small Size; 2. Fast Response; 3. UART output

### Application

For complete device development of household gas leak alarm.

### Parameters Table1.

Model No.	ZC05
Detection Gas	Natural gas
Type of sensor	Catalytic type
Detection Range	1%~25%LEL
Output	UART (0 or 3V)
Working Voltage	DC (5±0.1)V
Preheat Time	3min
Response time	≤ 10s
Resume time	≤ 30s
Working Current	(150±10) mA
Resolution	100ppm
Expected Lifespan	2 years
Working conditions	Temperature: -10~55 °C
	Humidity:20%~90%RH
Storage Conditions	Temperature: -10~55 °C
	Humidity:20%~65%RH

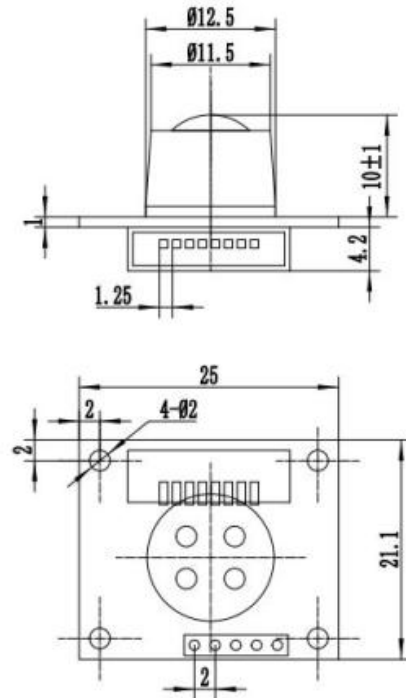

Unit:mm

Fig1. Module structure

## Description for pins

Pin No.	Description	<p>Fig2.Module pin</p>
Pin1	Vin	
Pin2	GND	
Pin3	Relay control, active High 1)Normal work status: low level for long 2)Alarm status: high level for long	
Pin4	UART(RXD) data receiver	
Pin5	UART(TXD) data transmitter(including defect information)	
Pin6	Solenoid valve control, active High 1)Normal work status: low level for long 2)Alarm status: pulse signal of high level for 500ms, low level for 500ms	
Pin7	Buzzer control, active High 1)Malfunction status: high level for 100ms, low level for 900ms 2)Alarm status: high level for 500ms, low level for 500ms	
Pin8	Preheating within 3 minutes: high level and low level in turn for 1s once; 1) Normal work status: high level for long 2) Malfunction status: low level for long.	

## Communication Protocol

### 1. General Settings

Table 3

Baud Rate	9600
Data Bit	8 bits
Stop Bit	1 bits
Check Byte	Null

### 2. Communication Commands

There are two kinds of communication, initiative upload mode and question & answer mode. Default settings is initiative upload mode. Modules upload gas concentration value every other 1S,

**Note:** 1. The module will automatically switch to Q&A mode (question & answer mode) after an inquiry command is received. 2. The module will automatically switch to initiative upload mode if no inquiry command is received within 30 seconds under Q&A mode.

Command line format of initiative upload as follow: **Table 4**

Byte0	Byte1	Byte2	Byte3	Byte4	Byte5	Byte6	Byte7	Byte8
Start Byte	Gas Name	Unit ppm	No. of decimal	Concentration (High Byte)	Concentration (Low Byte)	Full Range (High Byte)	Full Range (Low Byte)	Check sum
0xFF	0x01	0x03	0x00	0x00	0x00	0x30	0xD4	0xF8

Gas name: 0x01 is for CH4.

Concentration (High Byte): The highest bit (bit 8) is for sensor fault judgment;

Note: sensor fault judgment: Return 1 is for sensor failure, Return 0 is for no failure.

Gas concentration value = The low 6 bit of High Byte\*256+Low Byte.

Full range= full range (high byte)\*256+ full range(low byte) (0X30D4=12500, which means the module range is 12500ppm)

To read gas concentration, command line format as follow: **Table5.**

Byte0	Byte1	Byte2	Byte3	Byte4	Byte5	Byte6	Byte7	Byte8
Start Byte	Reserved	command	Reserved	Reserved	Reserved	Reserved	Reserved	Check sum
0xFF	0x01	0x86	0x00	0x00	0x00	0x00	0x00	0x79

Sensor's return value as follow: **Table6.**

Byte0	Byte1	Byte2	Byte3	Byte4	Byte5	Byte6	Byte7	Byte8
Start Byte	command	Concentration (High Byte)	Concentration (Low Byte)	Reserved	Reserved	Concentration (High Byte)	Concentration (Low Byte)	Check sum
0xFF	0x86	0x00	0x00	0x00	0x00	0x00	0x00	0x7A

Concentration (High Byte): The highest bit (bit 8) is for sensor fault judgment;

Note: sensor fault judgment: Return 1 is for sensor failure, Return 0 is for no failure.

Gas concentration value = The low 6 bit of High Byte\*256+Low Byte.

**3. Check sum and calculation**

```

unsigned char FucChecksum(unsigned char *i,unsigned char ln)
{
    unsigned char j,tempq=0;
    i+=1;
    for(j=0;j<(ln-2);j++)
    {
        tempq+=*i;
        i++;
    }
    tempq=(~tempq)+1;
    return(tempq);
}
    
```

## Installation instruction

This module connects with external part by adopting Pin1.25mm\*8 single-row inserting pin, there are four holes with 2mm diameters at the four corners, users fix the module through locations holes and make connection through Pin1.25mm\*8 wire.

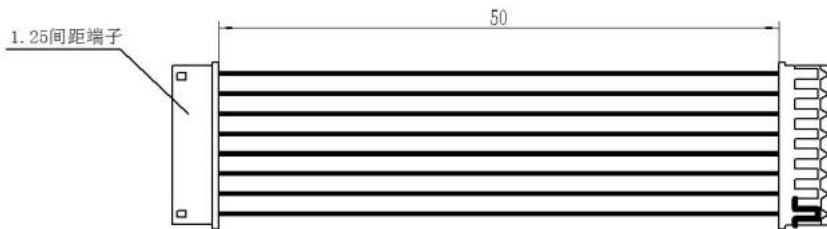

## Cautions

### 1 .Following conditions must be prohibited

#### 1.1 Exposed to organic silicon steam

Sensing material will lose sensitivity and never recover if the sensor absorbs organic silicon steam. Sensors must avoid exposing to silicon bond, fixture, silicon latex, putty or plastic contain silicon environment.

#### 1.2 High Corrosive gas

If the sensors are exposed to high concentration corrosive gas (such as H<sub>2</sub>S, SO<sub>x</sub>, Cl<sub>2</sub>, HCl etc.), it will not only result in corrosion of sensors structure, also it cause sincere sensitivity attenuation.

#### 1.3 Touch water

Sensitivity of the sensors will be reduced when splattered or dipped in water.

#### 1.4 Freezing

Do avoid icing on sensor's surface, otherwise sensing material will be broken and lost sensitivity.

### 2 . Following conditions must be avoided

#### 2.1 Water Condensation

Indoor conditions, slight water condensation will influence sensors' performance lightly. However, if water condensation on sensors surface and keep a certain period, sensors' sensitive will be decreased.

#### 2.2 Used in high gas concentration

No matter the sensor is electrified or not, if it is placed in high gas concentration for long time, sensors characteristic will be affected. If lighter gas sprays the sensor, it will cause extremely damage.

#### 2.3 Long time storage

The sensors resistance will drift reversibly if it's stored for long time without electrify, this drift is related with storage conditions. Sensors should be stored in airproof bag without volatile silicon compound. For the sensors with long time storage but no electrify, they need long galvanical aging time for stability before using. The suggested aging time as follow:

**Stable9.**

Storage Time	Suggested aging time
Less than one month	No less than 48 hours
1 ~ 6 months	No less than 72 hours
More than six months	No less than 168 hours

#### 2.4 Long time exposed to adverse environment

No matter the sensors electrified or not, if exposed to adverse environment for long time, such as high humidity, high temperature, or high pollution etc., it will influence the sensors' performance badly.

3. Please make sure the three anti-paint on the control board is completely dry before the module is installed.

4. Please do not plug the module under power-on condition.

**Zhengzhou Winsen Electronics Technology Co., Ltd**

**Add:** No.299, Jinsuo Road, National Hi-Tech Zone,  
Zhengzhou 450001 China

**Tel:** +86-371-67169097/67169670

**Fax:** +86-371-60932988

**E-mail:** [sales@winsensor.com](mailto:sales@winsensor.com)

**Website:** [www.winsen-sensor.com](http://www.winsen-sensor.com)