



Electrochemical CH₂O Detection Module
(Model: ZE08B-CH₂O)

User's Manual

Version: 1.1

Valid from: 2016.4.25

Zhengzhou Winsen Electronics Technology Co., Ltd

Statement

This manual's copyright belongs to Zhengzhou Winsen Electronics Technology Co., LTD. Without the written permission, any part of this manual shall not be copied, translated, stored in database or retrieval system, also can't spread through electronic, copying, record ways.

Thanks for purchasing our product. In order to allow customers better use our products and reduce the faults caused by misuse, please read the manual carefully and operate it correctly in accordance with the instructions. If users disobey the terms or remove, disassemble, change the components inside of the sensor, we shall not be responsible for the loss.

The specific such as color, appearance, sizes &etc., please in kind prevail.

We are devoting ourselves to products development and technical innovation, so we reserve the right to improve the products without notice. Please confirm it is the valid version before using this manual. At the same time, users' comments on optimized using way are welcome.

Please keep the manual properly, in order to get help if you have questions during the usage in the future.

Zhengzhou Winsen Electronics Technology CO., LTD.

Electrochemical CH2O Detection Module ZE08B-CH2O

Profile

ZE08B-CH2O is a general-purpose and miniaturization electrochemical formaldehyde detection module. It utilizes electrochemical principle to detect CH2O in air which makes the module with high selectivity and stability. It is built-in temperature sensor to make temperature compensation. It has the digital output and analog voltage output at the same time. It is a combination of mature electrochemical detection principle and sophisticated circuit design.



Features

- *High sensitivity & resolution, Low power consumption, Long life
- *UART output
- * Good stability, excellent ability of Anti-interference * Temperature compensation, Excellent Linear output

Main Application

Portable detector, air-quality monitor, air cleaner, air renewal system, air conditioner, smart home.

Technical Parameters Stable 1.

Model No.	ZE08B-CH2O
Target Gas	CH2O
Interference Gas	Alcohol, CO &ect.
Output	UART output(3V Electrical Level)
Working Voltage	3.7V~5.5V(With voltage reverse connect protection)
Warm up time	≤3 minutes
Response time	≤60s
Resume time	≤60s
Detection Range	0~1.6ppm
Resolution	≤0.01ppm
Operating Temp.	0°C~50°C
Operating Hum.	15%RH-90%RH(No condensation)
Storage temp.	0~25°C
Working life	2 years (in air)

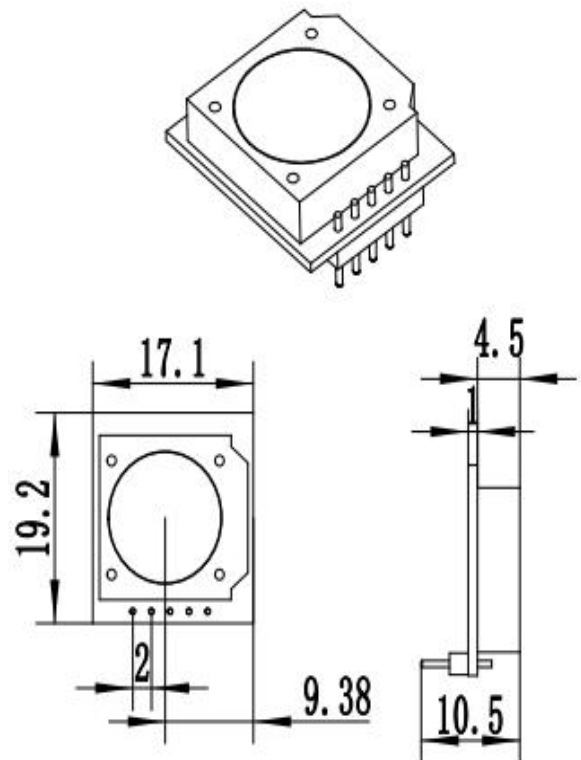

Fig 1: Module structure (module size tolerance $\pm 0.2\text{mm}$)

Pin Description:

Table 2

PIN	Instruction
Pin1	Vin(Voltage input 3.7-5.5V)
Pin2	UART (TXD) 0~3.3V data output
Pin3	UART (RXD) 0~3.3V data input
Pin4	GND
Pin5	Reserved

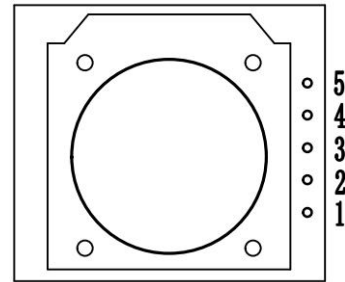

Fig2. Pin figure of the Module

Communication Protocol:

1. General Settings

Table 3

Baud Rate	9600
Data Bits	8 bytes
Stop Bits	1 byte
check bits	Null

2.Commands

There are two communication type: active upload type and Q&A type. The default type for this module is active upload and it sends gas concentration every other one second.

Active upload data display format is as follows:

Table 4

Byte0	Byte1	Byte2	Byte3	Byte4	Byte5	Byte6	Byte7	Byte8
Start Byte	Gas Name CH2O	Unit (ug/m3)	Decimal number(No)	Concentration (High Byte) (ug/m3)	Concentration (Low Byte) (ug/m3)	Full Range (High Byte)	Full Range (Low Byte)	Checksum
0xFF	0x17	0x04	0x00	0x00	0x18	0x07	0xD0	0xF6

Gas concentration value=High byte of concentration *256+ Low byte of concentration. (mg/m3)=(ug/m3)/1000

Switch to Q&A mode:

Table 5

Byte0	Byte1	Byte2	Byte3	Byte4	Byte5	Byte6	Byte7	Byte8
Start Byte	reserved	Switch command	Q&A	reserved	reserved	reserved	reserved	Checksum
0xFF	0x01	0x78	0x41	0x00	0x00	0x00	0x00	0x46

Switch to Active upload type:

Table 6

Byte0	Byte1	Byte2	Byte3	Byte4	Byte5	Byte6	Byte7	Byte8
Start Byte	reserved	Switch command	Q&A	reserved	reserved	reserved	reserved	checksum
0xFF	0x01	0x78	0x40	0x00	0x00	0x00	0x00	0x47

Read gas concentration under Active upload mode:

Table 7

Byte0	Byte1	Byte2	Byte3	Byte4	Byte5	Byte6	Byte7	Byte8
Start Byte	reserved	command	reserved	reserved	reserved	reserved	reserved	checksum
0xFF	0x01	0x86	0x00	0x00	0x00	0x00	0x00	0x79

The returned format is as follows:

Table 8

Byte0	Byte1	Byte2	Byte3	Byte4	Byte5	Byte6	Byte7	Byte8
Start Byte	command	High byte(ug/m3)	Low byte (ug/m3)	reserved	reserved	High byte (ppb)	High byte (ppb)	checksum
0xFF	0x86	0x00	0x2A	0x00	0x00	0x00	0x20	0x30

Gas concentration value=High byte of concentration *256+ Low byte of concentration

3 . Checksum and calculation

```

/*****
* Function Name: unsigned char FucCheckSum(uchar *i,uchar ln)
* Functional description: Sum check 【Take Not(Byte1+Byte2+...Byte7) +1】
* Function declaration: Take Not(Byte1+Byte2+...ByteX (X>2)

*****/
unsigned char FucCheckSum(unsigned char *i,unsigned char ln)
{
    unsigned char j,tempq=0;
    i+=1;
    for(j=0;j<(ln-2);j++)
    {
        tempq+=*i;
        i++;
    }
    tempq=(~tempq)+1;
    return(tempq);
}
    
```

Cross interference gas**Table 9**

Gas	Concentration	Equivalent CH ₂ O/ppm
NH ₃	50ppm	0ppm
C ₆ H ₆	100ppm	0.1ppm
Cl ₂	10PPM	0.1PPM
CH ₃ Cl	5PPM	0.1PPM
acetone	100PPM	0.2PPM
ETO	10PPM	0.5PPM
SO ₂	20ppm	0.8ppm
H ₂ S	100ppm	3.7ppm
H ₂	500ppm	5.5ppm
Ethanol	131ppm	5ppm
Methanol	42ppm	5ppm
formaldehyde	5ppm	5ppm

Cautions:

1. Sensor shall Avoid organic solvent, coatings, medicine, oil and high concentration gases
2. Excessive impact or vibration should be avoided;
3. Please keep the modules warming up for at least 5 minutes when first using.
4. Please do not use the modules in systems which related to human being's safety.
5. Please do not use the modules in strong air convection environment.
6. Please do not expose the modules in high concentration organic gas for a long time.

Zhengzhou Winsen Electronics Technology Co., Ltd**Add:** No.299, Jinsuo Road, National Hi-Tech Zone,
Zhengzhou 450001 China**Tel:** +86-371-67169097/67169670**Fax:** +86-371-60932988**E-mail:** sales@winsensor.com**Website:** www.winsen-sensor.com