



Carbon Monoxide Module

(Model No.: ZE15-CO)

Manual

Version: 1.1

Date of issue: 2018. 4. 12

Zhengzhou Winsen Electronics Technology Co., Ltd

Statement

This manual's copyright belongs to Zhengzhou Winsen Electronics Technology Co., LTD. Without the written permission, any part of this manual shall not be copied, translated, stored in database or retrieval system, also can't spread through electronic, copying, record ways.

Thanks for purchasing our product. In order to let customers use it better and reduce the faults caused by misuse, please read the manual carefully and operate it correctly in accordance with the instructions. If users disobey the terms or remove, disassemble, change the components inside of the sensor, we shall not be responsible for the loss.

The specific such as color, appearance, sizes &etc., please in kind prevail.

We are devoting ourselves to products development and technical innovation, so we reserve the right to improve the products without notice. Please confirm it is the valid version before using this manual. At the same time, users' comments on optimized using way are welcome.

Please keep the manual properly, in order to get help if you have questions during the usage in the future.

Zhengzhou Winsen Electronics Technology CO., LTD.

Electrochemical Carbon Monoxide Gas Module ZE15-CO

Profile

ZE15-CO is a general-purpose and miniaturization electrochemical carbon monoxide detection module. It utilizes electrochemical principle to detect CO in air which makes the module with high selectivity and stability. Built-in temperature sensor can do temperature compensation; and it has digital output and analog voltage output. It is a combination of mature electrochemical detection principle and sophisticated circuit design.

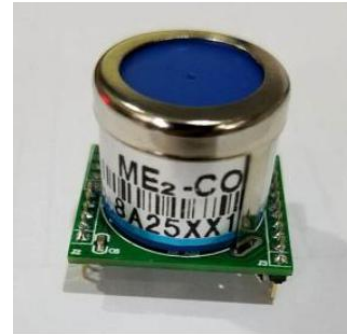

Features

High sensitivity, high resolution, low power consumption, long lifespan
 Supply UART, analog voltage signal output ways

Main Applications

Household CO alarm gas, smart home devices.

Technical Parameters Stable1.

Model No.	ZE15-CO
Detection gas	Carbon Monoxide (CO gas)
Interfering gases	Alcohol &etc.
Output data	UART output (0 or 3V)
Working voltage	5V~12V DC
Preheating time	30S
Response time	≤30S
Recovery time	≤30S
Detection range	0~500ppm
Resolution	0.1ppm
Working temperature	-10°C~55°C
Working humidity	15%RH-90%RH (no condensation)
Storage temperature	-10°C~55°C
Life span	3-5 year (in air)

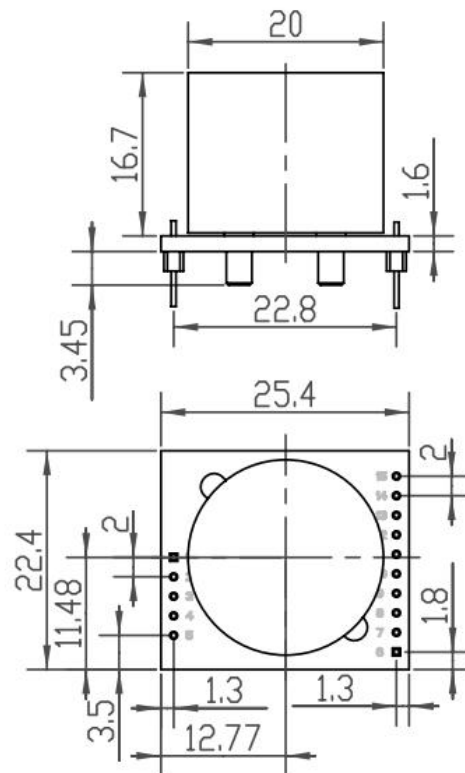
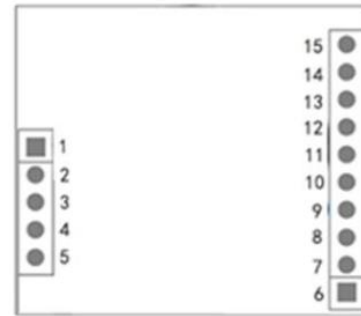

Fig1. Structure

Definition of pins Stable2.

PIN15	Vin (Input power 5~12V DC)
PIN5、PIN14	GND
PIN1	3.0V output
PIN3	Sensor fault output(1Hz, 10% duty cycle)
PIN4	Reserved
PIN6	Reserved
PIN7	UART (RXD) TTL 3V Electric Level
PIN8	UART (TXD) TTL 3V Electric Level
PIN9	Reserved
PIN10	Analog Voltage Output (0.4~2V is corresponded to 0~500ppm)
PIN2、PIN4、PIN11、	NC
PIN12、PIN13	Reserved



Stable2. Pins

Communication Protocol

1. General Settings

Table 3

Baud Rate	9600
Data Byte	8 bits
Stop Byte	1 bit
Check Byte	Null

2. Communication Commands

There are two kinds of communication, initiative upload mode and question & answer mode. Default settings is initiative upload mode. Modules upload gas concentration value every other 1S,

Note: The module will automatically switch to Q&A mode(question & answer mode) after an inquiry command is received; The module will automatically switch to initiative upload mode if no inquiry command is received within 30 seconds under Q&A mode.

Table 4 Initiative upload data format

Byte0	Byte1	Byte2	Byte3	Byte4	Byte5	Byte6	Byte7	Byte8
Start Byte	Gas Type	Unit (ppm)	No. of decimal	Concentration (High Byte)	Concentration (Low Byte)	Full Range (High Byte)	Full Range (Low Byte)	Check sum
0xFF	0x04	0x03	0x01	0x00	0x05	0x13	0x88	0x58

Gas name: 0x04 is for CO.

Concentration (High Byte): The highest bit(bit 8) is for sensor fault judgment;

Note: sensor fault judgment: 1 is for sensor failure, 0 is for no failure.

Gas concentration value = (The low 5 bit of High Byte*256+Low Byte)*0.1.

Full range= full range (high byte)*256+ full range(low byte) (0X1388=5000ppm, which means the module range is 500ppm)

To read gas concentration, command line format as follow: **table5.**

Byte0	Byte1	Byte2	Byte3	Byte4	Byte5	Byte6	Byte7	Byte8
Start Byte	Reserved	command	Reserved	Reserved	Reserved	Reserved	Reserved	Check sum
0xFF	0x01	0x86	0x00	0x00	0x00	0x00	0x00	0x79

Sensor's return value under Q&A Mode as follow: **table6.**

Byte0	Byte1	Byte2	Byte3	Byte4	Byte5	Byte6	Byte7	Byte8
Start Byte	command	Concentration (High Byte)	Concentration (Low Byte)	Reserved	Reserved	Concentration (High Byte)	Concentration (Low Byte)	Check sum
0xFF	0x86	0x00	0x05	0x00	0x00	0x00	0x05	0x7A

Concentration(High Byte): The highest bit(bit 8) is for sensor fault judgment;

Note: sensor fault judgment: 1 is for sensor failure, 0 is for no failure.

Gas concentration value = (The low 5 bit of High Byte*256+Low Byte)*0.1.

3. Check sum and calculation

Check = (negation(byte1+byte2+.....+byte7))+1

Please refer the following example:

```

unsigned char FucCheckSum(unsigned char *i,unsigned char ln)
{
    unsigned char j,tempq=0;
    i+=1;
    for(j=0;j<(ln-2);j++)
    {
        tempq+=*i;
        i++;
    }
    tempq=(~tempq)+1;
    return(tempq);
}
    
```

Cautions

1. DO NOT insert or extract the sensor on the PCB board.
2. DO NOT change or move the electronic part on the module.
3. Avoid sensor contact with organic solvent, coatings, medicine, oil and high concentration gases.
4. Excessive impact or vibration should be avoided.
5. Please keep the modules warming up for at least 5 minutes when first using.
6. Please do not use the modules in systems which related to human being's safety.
7. Please do not use the modules in strong air convection environment.
8. Please do not expose the modules in high concentration organic gas for a long time.

Zhengzhou Winsen Electronics Technology Co., Ltd

Add: No.299, Jinsuo Road, National Hi-Tech Zone,
Zhengzhou 450001 China

Tel: +86-371-67169097/67169670

Fax: +86-371-60932988

E-mail: sales@winsensor.com

Website: www.winsen-sensor.com